

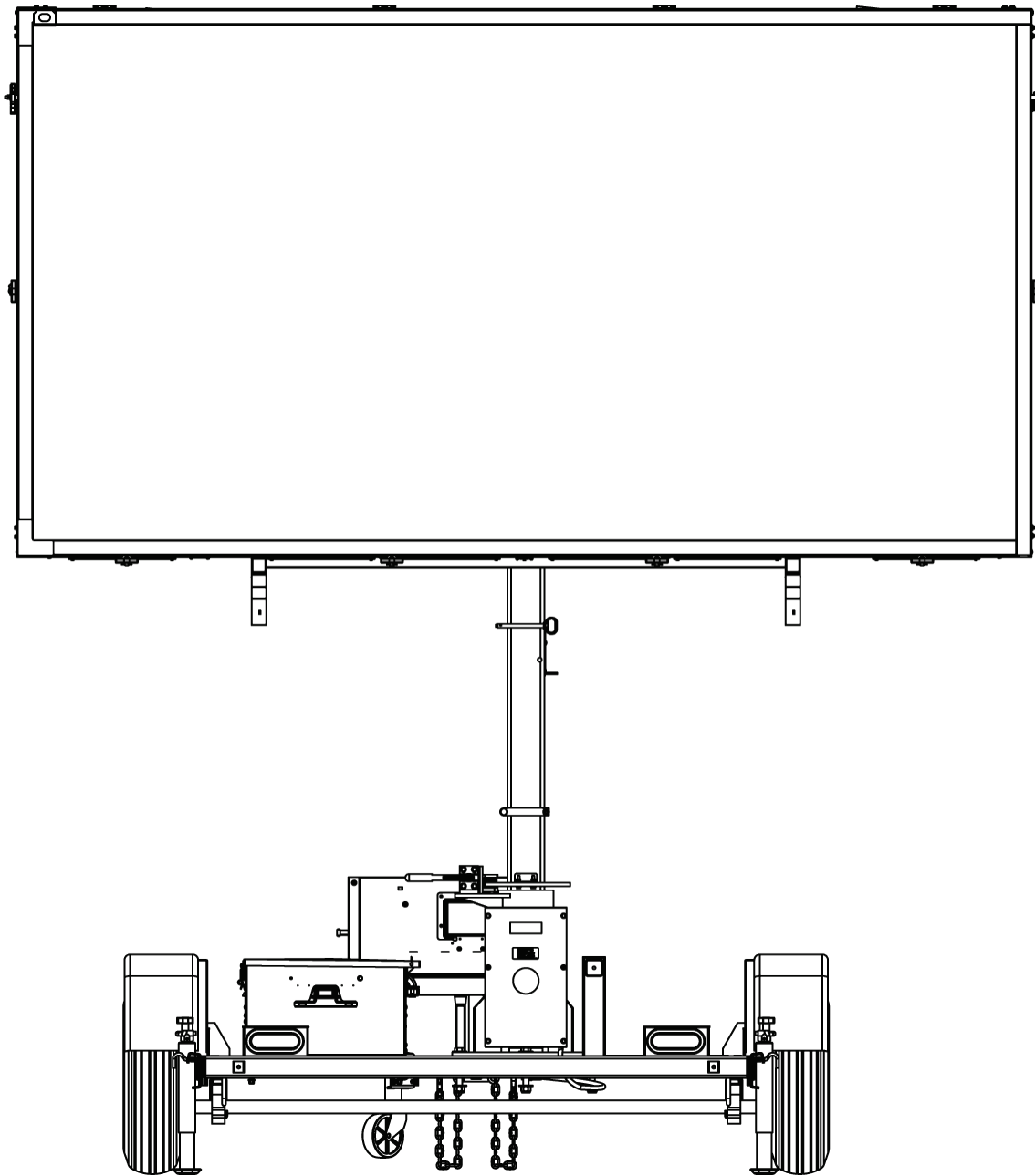

# THREE-LINE MESSAGE SIGNS

MODEL WTLMB  
PRODUCT SPECIFICATIONS | JANUARY 2014



## 1. DESCRIPTION

- 1.1. Description
- Wanco message signs provide information to the public on a large, legible LED display. These signs are portable and self-powered, requiring no permanent installation or wiring.
- The three-line display can present text messages of one, two, or three lines of up to eight characters per line. Messages are programmed using a self-contained onboard computer, making a laptop or external controller unnecessary. A laptop can be connected if desired. Signs come configured with preprogrammed standard messages, and users can create custom messages easily. A quick-message function provides for display of selected messages with a single keystroke.
- For optimal positioning, the sign rotates independent of the trailer and its height is fully adjustable. Jack-legs and optional outriggers provide more adjustability and added stability. The trailer is easy to maneuver and deploy, and can be towed by most vehicles.
- Power is provided by batteries, which are charged by an automated solar charging system.
- 1.2. Models
- 1.2.1. WTLMB(A) Full-size three-line message sign with hydraulic lift
- 1.2.2. WTLMB(B) Full-size three-line message sign with hand-operated winch

## 2. FEATURES

- 2.1. Setup
- Hydraulic lift raises sign display on tower
  - Tower rotates 360 degrees for optimal positioning
  - Single disk brake holds display in place during operation, while a cradle supports and holds display in travel position
- 2.2. Operation
- Self-contained onboard computer, no laptop required
  - Multi-level password protection restricts access to control software
  - Preprogrammed text messages
  - Quick-reference instructions, silkscreened on control panel, include most commonly performed tasks
  - Easily center each line of text
  - Internal clock facilitates built-in schedule programming
  - Multiple alphanumeric fonts
  - Optical lenses and sunshades increase visibility and performance
  - Wide footprint provides stability in high wind, while optional outriggers add even more support
  - Control box can be locked to prevent unauthorized access
  - Standard QWERTY keyboard can be removed and replaced
  - Meets MUTCD and NTCIP standards

- 2.3. Power system
- Energy-efficient operation results in long run times
  - Solar panels charge batteries automatically without intervention
  - System shuts down solar-panel charging system when batteries are fully charged, preventing damage
  - Power system allows battery charging with solar panels or commercial power
  - Cooling fans protect sign cabinet and battery charger from overheating
  - Battery box can be locked to prevent unauthorized access
- 2.4. Maintenance
- Individual display modules can be replaced easily
  - Standard trailer tires
  - Heavy-duty bolt-on steel fenders can be replaced if damaged
- 2.5. Application
- Common applications include:
- Roadwork zones
  - Traffic calming
  - Road closures
  - Emergency response
  - Public events

### 3. DISPLAY

#### 3.1. Cabinet

- 3.1.1. Description
- Weather-resistant cabinet contains display modules and related electronics. Hinged door with full-size display window protects electronics and provides access for maintenance. Clasps hold door closed during operation and can be locked with user-supplied padlock.
- Cabinet face is tapered five degrees downward (it is wider at the top than at the bottom) to face traffic, reducing glare.
- 3.1.2. Size
- 138" x 75" x 12" (351 x 189 x 30cm)
- 3.1.3. Material
- Aluminum sheet, 5052-H32, 0.062" (1.575mm) thick
- 3.1.4. Construction
- Panels are riveted together, with internal ribs to add lateral strength
- 3.1.5. Door
- Cabinet door is aluminum extruded frame with sheet metal corner brackets. Stainless steel butt hinges are bolted to top of cabinet and door.
- Window is anti-glare Lexan® solar-grade polycarbonate, 0.150" (3.81mm) thick. Bulb-type weather seal ensures tight fit and seal between window and door frame.
- When sign is in stored position, door fully opens to service the sign cabinet interior. Telescoping prop-slides, one on each side of the cabinet, hold door open.
- 3.1.6. Finish
- Cabinet and door are coated with oven-baked, flat-black, powder-coat finish to ensure durability and corrosion protection. Assemblies are high-pressure phosphate-washed prior to finish coat.

- 3.1.7. Wiring                      Wiring service loop from control box to display cabinet is routed inside liquid-tight loom and P-clamped to trailer frame. Service loop length is designed to allow 360-degree sign rotation. All wiring connectors and procedures are per CSA standards.
- 3.1.8. Ventilation                      Two cooling fans located at the top of the display cabinet circulate air into, through, and out of the cabinet to cool electrical components. A duct is located at the top of the cabinet to ensure even airflow.
- It is proven that electronic components, including LEDs, degrade in conditions of extreme heat. Without the cooling fans the display cabinet can reach over 200 degrees Fahrenheit.
- A temperature sensor is mounted on the photocell PC board inside the cabinet to control fan operation. Each fan has its own thermal settings, adjustable with the onboard computer, to optimize battery power usage.
- 3.1.9. Storage                      When lowered for storage and transport, the display cabinet rests in two support cradles, parallel to the trailer length, no locking pins required
- 3.2. Display panel
- 3.2.1. Description                      The display panel is comprised of a series of display modules laid out in a grid across the inside of the display cabinet. Each module has a matrix of LEDs installed on its face, which light up to show one character of the configured message. Each module features the necessary electronics and coatings to ensure outstanding performance and durability.
- 3.2.2. Display modules
- |                |  |
|----------------|--|
| Modular design | Allows any display module to be installed in any position in the matrix without repositioning DIP switches   |
| Wiring         | Modules have quick-connect electrical connectors for easy servicing. All wiring terminates at a single terminal strip inside the display cabinet.  |
| Replacement    | Each module can be exchanged in less than two minutes. The only tool needed is a 5/16-inch nut driver socket or slotted screwdriver<br><br>After a new module is installed, a one-step initialization process causes each module to sense its position in the full-matrix display. Initialization is accomplished using the sign's controller. |
| Firmware       | A program chip is socket replaceable for easy firmware upgrades  |
| Size           | 11.5" (29.2cm) wide by 18.0"(45.7cm) high, nominal   |
| Spacing        | 5" horizontal spacing, 6" vertical spacing   |
| Material       | FR4 glass-reinforced epoxy laminate, double-sided, black solder mask with white silkscreen<br><br>Board thickness, 0.094" (2.388mm)<br><br>Copper size, 1 oz. (28.4g)  |

	Coating	5-mil, military-spec, low-VOC, silicone conformal coating (Dow Corning 1-2577) provides long-term protection against moisture and other atmospheric contaminants, resists corrosion and shorts due to high humidity
	Vibration mounts	All display modules are mounted on rubber vibration-isolation mounts, decreasing risk of physical shock during transport and isolating characters from chassis ground
	Temperature limits	-40 to 176°F (-40 to 80°C)
	Humidity limits	Conformal coating rated to 95% relative humidity
3.2.3.	Pixels	Four LEDs form a "pixel"
	Pixel size	0.75" x 0.75" (19 x 19mm)
	Display module	5 x 7 pixels (W x H), 35 pixels total
	Pixel pitch	71mm, horizontal and vertical
3.2.4.	LEDs	Technology AllInGaP II (aluminum indium gallium phosphide) technology, T-1¾ size, through-hole auto-insertion
	Color range	Amber, 589.5 to 592 nm
	Current	100 mA peak-pulsed forward current
	Temperature limits	Operating temperature, -40 to 212°F (-40 to 100°C)
3.2.5.	Lenses and visors	<p>Each pixel has a snap-in optical lens over the LEDs, enhancing the brightness and angularity of each pixel while reducing power consumption. A polycarbonate visor shades each row of pixels to eliminate glare caused by direct sun exposure. The sunshades snap onto the display module without tools. The lenses snap into the sunshades.</p> <p>These enhancements enable the message sign to operate with approximately half the power consumption of other message signs. As a result, the system is fully functional using fewer solar panels and batteries, while providing outstanding brightness and readability in all lighting conditions, and 30-day battery autonomy without sun. Reducing the number of solar panels and batteries also lowers the trailer weight and reduces maintenance costs.</p>
3.2.6.	Visibility	4800 ft. (1463m) per 2008 NTPEP results
3.2.7.	Legibility	Word recognition with default font, 918 to 1031 ft. (280 to 314m) per 2008 NTPEP results
3.2.8.	Viewing angle	Total viewing area with optical lenses, 25.0 to 48.8 degrees per 2008 NTPEP results
3.2.9.	Brightness	Factory preset for optimal viewing and power consumption

- 3.2.10. Auto dimming Two photocells detect ambient light on the message sign; the message sign computer adjusts the brightness of the LEDs accordingly, dimming display brightness in darkness, increasing to full brightness in daylight  
Photocells are mounted inside the sign cabinet, one facing rear and one facing front
- 3.2.11. Software design
- |            |   |
|------------|---|
| Driver     | LEDs controlled through 30mA pulse-width modulation design  |
| Addressing | Each display module address is selected through a software command; no DIP switches are used. The address does not change until reprogrammed, preventing the message from shifting due to an individual module failure. |
| Pixel test | Each module is equipped with individual pixel failure notification  |
- 3.2.12. Font 5 x 7 pixels (W x H), 11.93" x 17.52" (30.3 x 44.5cm), maximum 3 lines of 8 letters per line
- 3.3. Standards Meets MUTCD standards

#### 4. CONTROL CONSOLE

- 4.1. Description Self-contained onboard computer for programming and running sign display. No laptop computer required. Located inside a locking control box near front of trailer. Operator can sit on trailer frame while using the computer. A laptop with Wanco software can be connected if desired.
- 4.2. Control box
- 4.2.1. Rating NEMA 4 (IP53) type, dust and weatherproof steel box
- 4.2.2. Size 24.0" x 16.0" x 9.5" (61.0 x 40.6 x 24.1cm) W x H x D
- 4.2.3. Material 14ga CRS
- 4.2.4. Door Front-panel is a door, hinged at the bottom, which drops down when opened.  
A bracket inside the door holds the computer operation manual, which has pages made of synthetic paper for resistance to wet weather conditions.
- 4.2.5. Latch Handle on front of control box door operates three-point latching mechanism to keep hinged door closed. Handle is keyed and can be locked.
- 4.2.6. Finish Cabinet and door are coated with oven-baked, equipment-white, powder-coat finish to ensure durability and corrosion protection. Assemblies are high-pressure phosphate-washed prior to finish coat.
- 4.2.7. Serviceability Entire console box is removable for service; all wiring has quick-connect plugs
- 4.2.8. Console light A nightlight inside control box is controlled by magnetic reed switch on door, and illuminates the control panel and manual area for nighttime reading. Light shuts off automatically after a period of keyboard inactivity.

- 4.3. Control panel
  - 4.3.1. Operating instructions Easy-to-follow instructions are silkscreened on front of control panel for easy reference while using the computer. No stickers or decals. Silkscreen is durable and long-lasting.
  - 4.3.2. Display
    - An LCD displays menus and status information, providing interactivity with the sign.
    - Full matrix LCD, four lines of up to 20 characters per line
    - Large pixel size with good angularity for better viewing
    - Rotary switch adjusts LCD brightness for optimum viewing
    - LCD has green LED backlighting
    - The LCD automatically shuts off after a period of inactivity; a push-button switch activates the LCD
    - Temperature limits: -4 to 158°F (-20 to 70°C)
  - 4.3.3. LED indicators
    - Indicates the status conditions. Depending on user-specified message sign options, may include one or more of the following:
      - Active alarms
      - Message sign power is on
      - Solar charging system is charging batteries
      - Programmed schedule is active
      - Radar power is on
      - Highway radio is on
      - Low battery voltage detected, system power shutdown occurred
- 4.4. PC boards
  - 4.4.1. Data ports 5 serial ports; 2 USB ports, 1 Ethernet port
  - 4.4.2. Coating 100% coated with military-spec, low-VOC, silicone conformal coating to provide long-term protection against moisture and other atmospheric contaminants. Resists corrosion and shorts due to high humidity.
  - 4.4.3. Temperature limits -4 to 176°F (-20 to 80°C)
  - 4.4.4. Humidity limits Conformal coating rated to 95% relative humidity
- 4.5. Keyboard Detachable standard desktop-computer keyboard, IBM compatible, 101 USB connection
- 4.6. Controller software
  - 4.6.1. Standards Fully NTCIP-compliant
  - 4.6.2. Security Three levels of password protection
  - 4.6.3. Message programming
    - Instant access to program new messages
    - Extremely easy to program

4.6.4. Message types	Quick-messages	One-click quick-message activation using keyboard function keys
	Permanent	Over 90 preprogrammed permanent messages, including arrows and FHWA standards  One-click activation using keyboard function keys
	Changeable	250 changeable messages stored in NV flash  One-click activation using keyboard function keys
	Temporary	10 temporary or volatile messages, for ITS systems
	Blank	One-click sign blanking/power off
4.6.5. Interface display	WYSIWYG (What You See Is What You Get) while programming	
4.6.6. Text alignment	Selectable: left, center, or right	
4.6.7. Blinking	Each character can individually blink	
	Individual lines of a multi-line message can blink	
	The entire message can blink	
	Adjustable timing and duty cycle	
4.6.8. Message pages	Maximum 10 sequential “pages” per message, sequencing speed from 0.1 to 25.5 sec.	
4.6.9. Scheduling	Real-time clock and calendar with DST control	
4.6.10. Arrow board functions	Sign can display any of the following 12 full-size arrow functions	
	Modes	Flashing left or right arrow Flashing double arrow Flashing four-corner warning Flashing caution-bar warning Sequencing left or right arrow Sequencing left or right stem arrow Sequencing left or right chevron arrows Alternating diamonds  (for samples, see Exhibit A)
	Bold graphics	Each arrow and bar is 5 pixels wide
	One-click activation	All modes can be activated using keyboard function keys
4.6.11. Configuration	Menus provide access to all message sign configuration settings	
4.6.12. Troubleshooting	Status and diagnostic menus provide message sign information to assist in troubleshooting	



## 5. TRAILER

- 5.1. Frame All welded structural steel
- 5.2. Fenders Rectangular Jeep-style fenders are bolted to the trailer frame  
Material: 16ga steel
- 5.3. Tie-downs One on each corner of frame
- 5.4. Finish Frame is coated with oven-baked, safety-orange powder-coat finish to ensure durability and corrosion protection. Assemblies are run through a five-stage, high-pressure phosphate-wash prior to finish coat.  
See "Options and Optional Equipment" for color options.
- 5.5. Traction tape Traction tape on top of frame, sign side only, prevents slipping when standing on the frame to service sign
- 5.6. Axle assembly 3500 lb. (1588kg) capacity, 4" (10cm) drop-axle, 5 on 4.5" B.C. idler hub  
See "Options and Optional Equipment" for brake options
- 5.7. Springs Double-eye leaf springs
- 5.8. Tires ST205/75D15 steel-belted trailer tires, load rating B
- 5.9. Drawbar
- 5.9.1. Construction Straight square tubular steel, 3" x 3/16" wall (7.62cm x 0.476cm wall), integrated into trailer frame
- 5.9.2. Jack Top-wind swivel, 800-lb. (363kg) capacity with caster wheel to make moving trailer easier
- 5.9.3. Tow hitch Standard 2-inch ball coupler tow-hitch, SAE Class 2, 3500-lb. (1588kg) capacity. Bolts to drawbar, removable and replaceable.  
See "Options and Optional Equipment" for tow-hitch options.
- 5.9.4. Tow chains Two high-test proof coil chain assemblies, with "latching" S-hooks for towing. Chains attached to drawbar with quick connectors.
- |                    |                    |
|--------------------|--------------------|
| Material diameter  | 0.406" (10.3mm)    |
| Working load limit | 5400 lbs. (2450kg) |
| Breaking force     | 16,200 lbs. (72kN) |
- 5.10. Stabilizer jacks Four swivel jacks, each with 2000-lb. (907kg) capacity, mounted on corners of trailer frame  
See "Options and Optional Equipment" for outriggers

- 5.11. Wind resistance In the deployed position, the maximum sustainable wind speed before overturning, when supported by the standard jack stands with tires off the ground, is 72 mph (115km/h)
- 5.12. Wiring
  - 5.12.1. Tow-vehicle plug Two-piece assembly with 4-flat molded connector on harness plugs into tow vehicle  
Meets SAE J1239  
See "Options and Optional Equipment" for tow-vehicle plug options
  - 5.12.2. Protection All trailer wiring encased in UV protective loom, and attached with P-clamp riveted to trailer frame; no exposed wires
- 5.13. Taillights
  - 5.13.1. Type Two oval-shaped, sealed, combination stop, turn and taillights
  - 5.13.2. Location Mounted to top of trailer deck behind fenders
  - 5.13.3. Mounting No screws used for mounting; bracket is welded to trailer frame; each light held in place and sealed with snap-in rubber grommet
- 5.14. License plate A lighted license plate light holder is mounted to rear trailer frame
- 5.15. Reflectors Sides of trailer have amber reflectors near front and red reflectors near rear  
See "Options and Optional Equipment" for reflective tape
- 5.16. Tower assembly
  - 5.16.1. Function Sign cabinet is raised and lowered on a telescoping tower
  - 5.16.2. Tower construction Two sections of square steel tubing with the inner section telescoping inside the outer section. The inner section is zinc plated to prevent corrosion.  
  
Nylon guide blocks keep the sections tight, eliminating the need for greasing the tower and preventing dirt from building up on the inner tower section. Dirt would cause performance problems and maintenance issues.
  - 5.16.3. Swivel base A steel tubular weldment is bolted to the trailer frame. The outer tower section rotates on a thrust bearing and washers inside the swivel base, reducing rotating friction.
  - 5.16.4. Height At fully deployed height, 84" (213cm) from ground to bottom of display cabinet
  - 5.16.5. Height lock
    - Winch model Spring-loaded locking pin prevents tower from falling if the winch or cable were to fail. Also locks tower when fully lowered into travel position.
    - Hydraulic lift model Locking pin inserted through the tower in the up position prevents the tower from falling if the hydraulics were to fail. Replaces spring-loaded locking pin.

5.16.6. Winch assembly (winch model only)	Function	Hand-operated winch raises and lowers sign cabinet	
	Capacity	2500 lbs. (1134kg)	
	Brake	Safety friction-brake prevents display cabinet from falling if operator loses grip on winch handle	
	Cable	1/4" (6.35mm) diameter galvanized aircraft cable	
5.16.7. Hydraulic lift (hydraulic model only)	Function	Raises display cabinet with a hydraulic power unit that pressurizes a cylinder; lowered by controlled gravity return. Control switch for hydraulic lift is located inside control box.	
	Hydraulic cylinder	Single stage hydraulic, rated to 1500 psi, bottom end cap is keyed to prevent cylinder from rotating	
	Hydraulic power unit	Type	Electric motor driven See "Options and Optional Equipment" for hand pump
		Voltage	12Vdc
		Flow rate	1.5 gpm
		Pressure rating	Factory set to 950 psi
		Mounting	Installed vertically on bracket that is mounted to swivel base
		Fluid	AW-32 hydraulic oil
		Tank capacity	1.2 gal. total, 0.766 gal. usable capacity
		Cover	Sheet metal cover protects power unit from vandalism and environmental contaminants. Security screws fasten cover to power unit.
5.16.8. Rotation		Sign rotates by hand, pivoting 360 degrees on tower	
5.16.9. Rotation lock		Sign rotation is locked with an adjustable lever that operates a mechanical friction caliper and disk brake. The ½-inch thick, round, zinc-plated brake disk is bolted to the outer tower section.	
5.16.10. Sight tube		A sight tube for aiming the message sign in desired direction is mounted to tower mast	

## 6. POWER SYSTEM

- 6.1. Description Electronics powered by batteries, which are charged automatically with integrated solar charging system
- 6.2. Battery box
  - 6.2.1. Function Holds batteries and remote charger  
See “Options and Optional Equipment” for heavy-duty secure battery box
  - 6.2.2. Construction Riveted all-steel construction  
All parts powder-coated before assembly  
Divider panel inside box separates batteries from electronics  
Louvers provide ventilation  
Latches keep cover closed and can accept user-supplied padlocks
  - 6.2.3. Location Centered over axle on left side of trailer, bolted to trailer frame
- 6.3. Batteries
  - 6.3.1. Description Four deep-cycle Group 24 batteries, wired in parallel and series for a 12-volt system  
See “Options and Optional Equipment” for battery options
  - 6.3.2. Voltage 6Vdc each
  - 6.3.3. Weight Approx. 60 lbs. (26kg) each
  - 6.3.4. Capacity 430 Ah total capacity @ 12Vdc
- 6.4. Remote charger
  - 6.4.1. Function Plugs into a standard commercial power source to recharge batteries if battery voltage drops due to lack of sun for automated solar charging system
  - 6.4.2. Type 12-volt battery charger
  - 6.4.3. Location Inside battery box, mounted to divider panel on opposite side from batteries
  - 6.4.4. Output capacity 15A
  - 6.4.5. Output voltage 13.2Vdc range “float” mode  
13.6Vdc range “absorption” mode  
14.2Vdc range “bulk” mode
  - 6.4.6. Input voltage 105 to 135Vac, standard three-prong plug
  - 6.4.7. Input frequency 50 to 60 Hz

- 6.4.8. Cooling Fan cooled when charger temperature reaches 95°F (35°C)
- 6.4.9. Protection Automotive-style replaceable fuses
- 6.5. Solar
  - 6.5.1. Panels One high-efficiency multi-crystal photovoltaic solar module  
See “Options and Optional Equipment” for solar options
  - 6.5.2. Location Behind message sign, over tower. Solar panel array lies flat; rises and rotates with message sign. No shadowing effect on any trailer component.
  - 6.5.3. Power output 130W  
See “Options and Optional Equipment” for solar power options
  - 6.5.4. Current 9.5A max. system current  
10.3A open short-circuit current
  - 6.5.5. Voltage 17.9Vdc max.  
21.8Vdc open short-circuit voltage
  - 6.5.6. Regulation Solar panels regulated by computer power board
  - 6.5.7. Security Solar panel array bolted to message sign frame with security screws and special security nut. Tool for security screws mounted inside control box.

## 7. DIMENSIONS & WEIGHT

### 7.1. Dimensions *inches (cm)*

#### Travel position

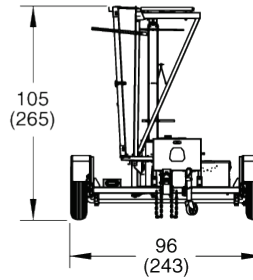
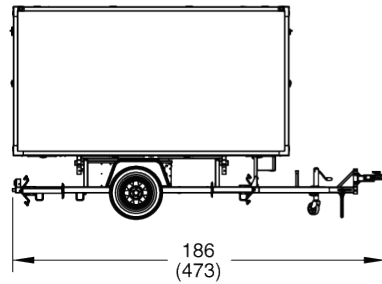

#### Deployed

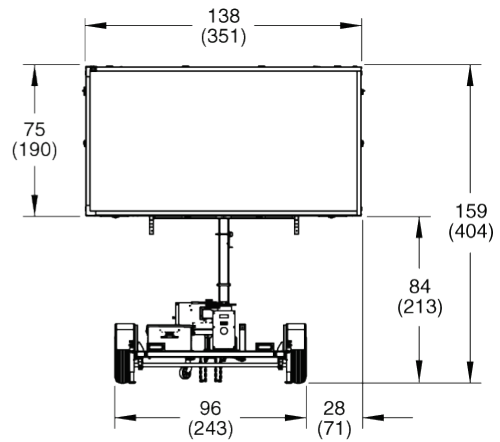
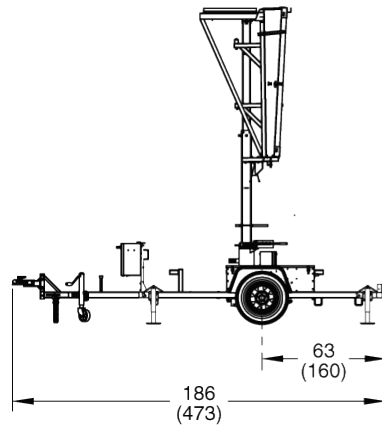

### 7.2. Weight **Approx. 2640 lbs. (1193 kg)**

## 8. OPTIONS AND OPTIONAL EQUIPMENT

### 8.1. Tow hitch

8.1.1. Combo hitch                      Combo-hitch for pintle hook and 2-inch ball hitch  
Heavy-duty lunette ring, 3" ID x 1 $\frac{5}{8}$ " cross-section

8.1.2. Lunette ring                      Heavy-duty lunette ring for pintle hook, 3" ID x 1 $\frac{5}{8}$ " cross-section

8.2. **Tow-vehicle plug**                Many types of plugs available, prewired at the factory; contact factory for details

### 8.3. Brakes

8.3.1. Hydraulic                      Hydraulic surge brakes

8.3.2. Electric                          Electric brakes

8.4. **Outriggers**                      Telescoping outriggers (jack extensions), one at each corner of the trailer, expand trailer width when deployed, for extra wind-load resistance  
  
Width of trailer with outriggers extended: 126" (320cm)

### 8.5. Power

8.5.1. Additional batteries            For geographic locations with less solar charging potential or colder weather, and for applications that require year-round charging, add batteries for greater capacity  
  
Options                      Two additional 6Vdc deep-cycle batteries, 215Ah additional capacity  
                                    Four additional 6Vdc deep-cycle batteries, 430Ah additional capacity  
                                    Six additional 6Vdc deep-cycle batteries, 645Ah additional capacity

8.5.2. AGM batteries                    Replace deep-cycle batteries with top-of-the-line absorbed glass mat (AGM) batteries

Features                      100% maintenance-free  
  
                                    Sealed and spill-proof  
  
                                    Faster recharge and greater freeze resistance than conventional batteries  
  
                                    Contains less lead than conventional batteries  
  
Options                      Two 4D AGM 12Vdc batteries, 400Ah total capacity  
                                    Three 4D AGM 12Vdc batteries, 600Ah total capacity  
  
Weight                          Approx. 160 lbs. (72kg) each

- 8.5.3. Remote charger When required for added battery charging capacity, replace standard remote charger with higher amperage charger
- Options 12-volt, 45-amp charger  
12-volt, 75-amp charger
- Details Output voltage 13.4Vdc @ full load  
13.6Vdc standard float voltage  
14.2Vdc with dual-voltage jack installed
- Input voltage 108 to 132Vac, standard three-prong plug
- Input frequency 50 to 60 Hz
- 8.5.4. Solar For geographic locations with less solar charging potential or colder weather, and for applications that require year-round charging, additional solar power is available
- Options include 170W, 215W, 260W, and 390W solar arrays; contact factory for details
- 8.6. Hand pump A mechanical hand pump can raise and lower the sign if batteries go dead and hydraulic lift fails to operate. Pump handle is stored inside battery box.
- 8.7. Secure battery box
- 8.7.1. Battery box High-security battery box features heavy-gauge steel lid, hidden hinges, and heavy-duty hidden-shackle padlocks. Replaces standard battery box.
- 8.7.2. Crossbar Optional heavy-duty, lockable crossbar fits over top of secure battery box, preventing lid from opening
- 8.8. Taillights
- 8.8.1. Dual sealed-bulb Dual sealed-bulb taillights replace standard sealed-bulb taillights
- Requires SAE J560 7-pole round-pin trailer plug to replace standard trailer plug
- 8.8.2. Single LED Single LED taillights replace standard sealed-bulb taillights
- 8.8.3. Dual LED Dual LED taillights replace standard sealed-bulb taillights
- Requires SAE J560 7-pole round-pin trailer plug to replace standard trailer plug
- 8.9. Reflective tape Reflective red-and-white conspicuity tape across rear trailer frame for increased visibility
- 8.10. Finish color Specify power-coat color and, if applicable, color scheme



### 8.11. Radar-based speed monitoring system

8.11.1. Description	Approach-only radar senses the largest moving mass moving toward it. The message sign conveys a user-selected message to the motorist.
8.11.2. Band	K-band transmitter
8.11.3. Location	Radar head located on the bottom of the message sign display cabinet, just off-center, for maximum effectiveness regardless of which side of the road the trailer is being used
8.11.4. Enclosure	Radar head is sealed to withstand the elements, while an aluminum cover goes over the head unit for impact resistance
8.11.5. Standards compliance	FCC approved CE compliant
8.11.6. Distance range	1000 ft. @ 5 to 85 mph (305m @ 8 to 137km/h)
8.11.7. Speed range	5 to 99 mph (8 to 222km/h)
8.11.8. Accuracy	±1 mph from 5 to 40 mph, ±2 mph from 40 to 100 mph (±1.6km/h from 8 to 64km/h, ±3.2 from 64 to 161km/h)
8.11.9. Frequency	24.150 ± 0.05 GHz
8.11.10. Electrical protection	Fused and reverse-polarity protected
8.11.11. Calibration	Radar is factory calibrated; a tuning fork for verifying radar is operating correctly is attached inside the control cabinet door; when struck and held in front of the radar head, the tuning fork vibrations simulate 55 mph

### 8.12. Cellular modem package

8.12.1. Purpose	The remote communications package enables the message sign to be controlled from remote locations away from the message sign, using an Internet-connected computer, tablet, or smartphone. Includes all of the items described below.	
8.12.2. Remote NTCIP central control software	Description	Easy-to-use program connects a computer to an individual message sign via an Internet connection. Used for changing messages, checking on trailer health status (such as battery voltages), viewing GPS locations, and setting message schedules.
	System requirements	Microsoft® Windows® (most versions) .NET framework Internet connection
	Description	Using a standard Web browser, allows connection to an individual message sign without software. Ideal for smartphone users.

	System requirements	<p>Modern standards-compliant Web browser (such as Mozilla® Firefox®, Microsoft Internet Explorer® 7, Opera™, or Safari®) with JavaScript enabled</p> <p>A platform that supports one of these browsers (smartphone, laptop computer, or desktop computer)</p> <p>Internet connection</p>
8.12.4. Wanco Fleet Manager	Description	Web-based application for managing even the most diverse message sign fleets
	Features	<p>Add or remove equipment to groups for quick access, ideal for managing contractor rentals or entire projects all at once</p> <p>Map GPS locations of entire message sign fleet simultaneously</p> <p>Record vital information from signs, such as message changed by user and date, battery and solar voltages, and equipment alarms</p> <p>Mass broadcast capability, perfect for Amber Alerts and emergencies</p>
	System requirements	<p>Modern standards-compliant Web browser (such as Mozilla Firefox, Microsoft Internet Explorer 7, Opera, or Safari)</p> <p>A platform that supports one of these browsers (laptop or desktop computer)</p> <p>Internet connection</p>
8.12.5. Cellular plans	User provided	User obtains cellular data plan from, and makes monthly payments to, service provider. Wanco programs modem according to user-provided specifications at time of modem purchase. Wanco tests modem setup.
	Wanco cellular service	Wanco provides Verizon® cellular service without activation charges, monthly payments, or overage charges. User makes a single payment annually to Wanco. For increased security, Wanco hosts the service on a virtual private network (VPN).
8.12.6. Modem	Compact industrial cellular gateway	
	Optional modems available; contact factory for details	
	Carriers	Approved for use on Verizon, AT&T®, Sprint®, Rogers™, Bell™, and Telus®
	Security	Latest levels in security, IP sec, SSL, and GRE VPN client
	Power	<p>Input voltages range: 7 to 28Vdc</p> <p>Typical power consumption: 250mA @ 12Vdc</p>
	Operating temperature	-22 to 158°F (-30 to 70°C)

8.12.7. Antenna	Low-profile dual-function GSM/GPS
	Location Installed at highest point on message sign
	GPS L1 antenna 1575.42 ±3 MHz center frequency <15mA @ 3 to 5V
	GSM antenna Dual band, 824 to 896 MHz and 1710 to 1990 MHz
	Connectors SMA connectors for GSM and GPS antennas

### 8.13. Traffic Data Classifier System

8.13.1. Design	Radar-based, nonintrusive, does not require loops or hoses, no disturbance of traffic flow during installation or use
8.13.2. Direction	Registers both approaching and receding vehicles
8.13.3. Traffic lanes	Most effective for 2-lane roads
8.13.4. Traffic count	Can record data for more than 1 million vehicles in internal memory
8.13.5. Data format	Speed, date, time, direction, length for each vehicle
8.13.6. Units	English or metric
8.13.7. Time stamp	Yr,Mo,Dy,Hr,Min,Sec.
8.13.8. Speed range	5 to 138 mph (8 to 222 km/h)
8.13.9. Sensor	Microwave K-band 24.125 GHz
8.13.10. Power	Uses radar-speed sign power supply
8.13.11. Power output	20 dbm (EIRP)
8.13.12. Current	110 mA
8.13.13. Temperature	Operating limits: -40 to 185 °F (-40 to 85 °C)
8.13.14. Internal memory	1MB (1,048,576 bytes)
8.13.15. Baud rate	9600, 8 bit, no parity
8.13.16. Calibration	Self-calibrating
8.13.17. Installation	Automatically positioned horizontally when trailer is level; adjustable bracket allows user to point toward traffic at a 45-degree angle

**8.14. RemoteUI control software**

- |                             |   |
|-----------------------------|---|
| 8.14.1. Description         | The Wanco RemoteUI program allows operators to control the message board using a laptop computer or touchscreen device. The computer must be connected to the message sign; wireless access is not recommended. |
| 8.14.2. Fleet limits        | Connects to one sign at a time; maximum number of signs is unlimited  |
| 8.14.3. Security            | Multi-level password protection   |
| 8.14.4. System requirements | Computer requires Microsoft Windows (most versions) or Unix® operating system<br>Message sign requires cellular modem package   |

## EXHIBIT A

### Arrow board functions

#### Flashing patterns



Flashing left or right arrow



Flashing double arrow



Flashing four-corner warning



Flashing caution-bar warning

#### Sequential patterns



Sequencing left or right arrow



Sequencing left or right stem arrow



Sequencing left or right chevron arrows



Alternating diamonds