

PICK & CARRY CRANE



MC 25 - Max capacity 5500 lb



Electric by battery

MC 25

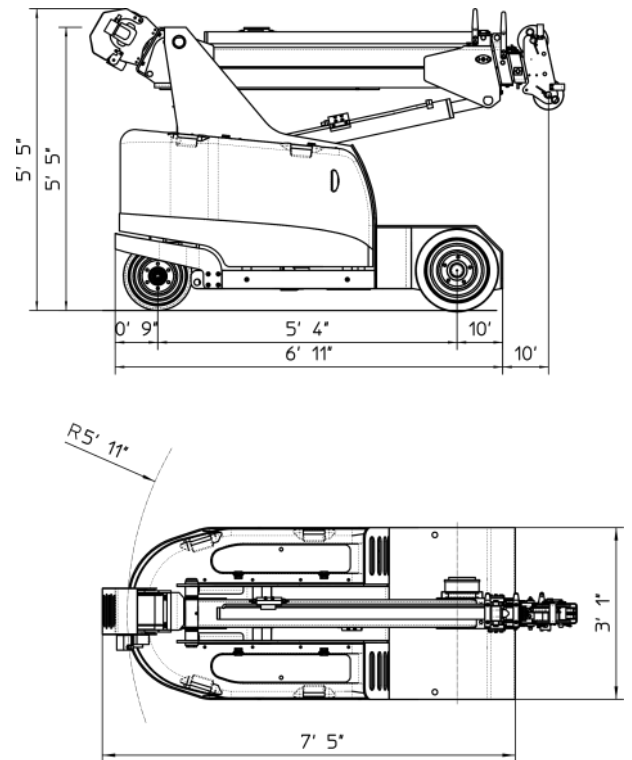
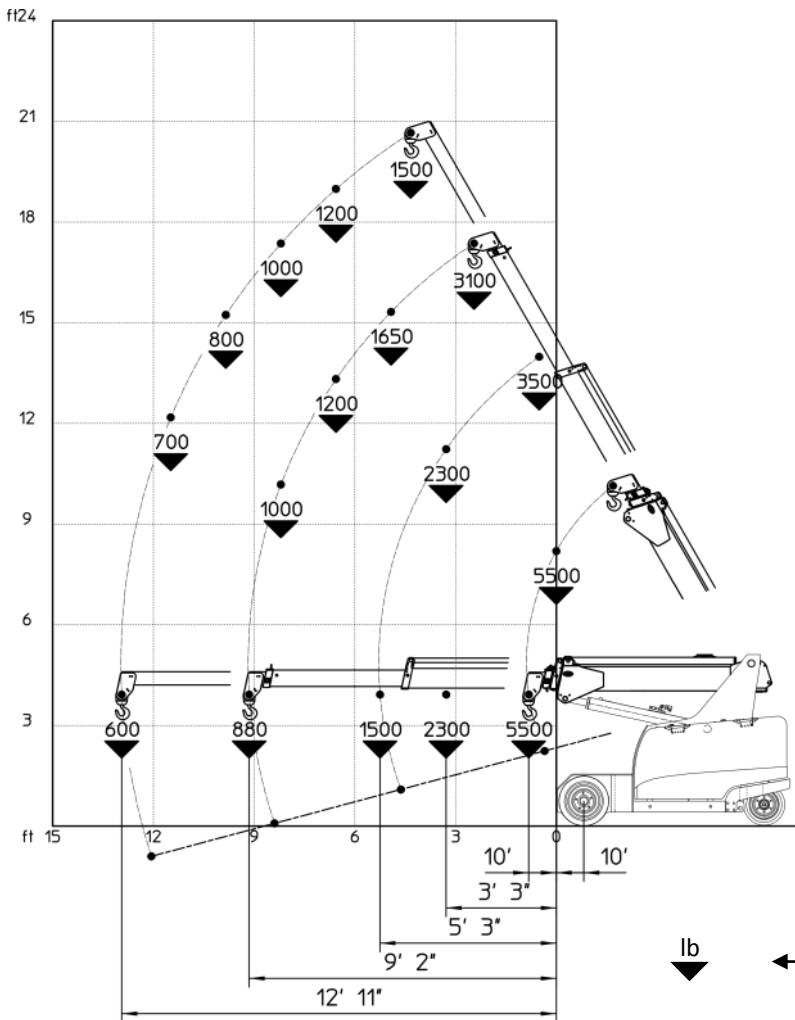

lb ft.

MODEL	MC25
CRANE CLASSIFICATION ACCORDING TO UNI ISO 4301-1	A3
REFERENCE STANDARDS	2006/42 CE - 2004/108 CE I.S.P.E.S.L. DIN 15018 (1,3) - 15019 (1) Class H2 B3 ANSI B30.5 - 2007 and subsequent modifications
TRACTION	Electric
BOOM ACTIVATION	Hydraulic
POWER TYPE	Electric battery
MAX. CAPACITY (lb)	5500
TOTAL WEIGHT (lb)	5060
BOOM ANGLE TOPSIDE (°)	60
BOOM ANGLE DOWNSIDE (°)	-15

FRAME: JMG designed and manufactured, box type, torsion resistant design of high strength structural steel.

BOOM: Made of moulded and welded quality steel plate, comprised of a base unit, a hydraulic telescopic system and two manual extensions.

MOTOR: 2 Electric motors 2 kW 24 V AC

BATTERY: 24 V 420 Ah battery charging indicator.

TRANSMISSION: n.2 wheels drive at the front side.

WHEELS: Front: 2 Superelastic 18x7x8" - Rear: 2 Superelastic 15x4^{1/2}x8".

BRAKING: Automatic on the rear wheels.

STEERING: Steering on the rear wheels by electric motor. Max. steering angle $\pm 90^\circ$.

TRAVEL CONTROL: Operated by radio remote console.

ELECTRIC PUMP: 2,5 kW 24 V DC motor

HYDRAULIC SYSTEM: Hydraulic system powered by a silenced gear pump. Actuators controlled by electro-proportional distributor with joystick. Filter and safety valve. 22 MPa max. working pressure.

SAFETY DEVICES: Electronic load moment indicator.

OPTIONAL EQUIPMENT (at extra charge) - Hydraulic winch - High speed winch - Jib - Non-marking wheels - Hydraulic boom with manual extension - Man basket - Hydraulic chain hoist.