

Ultra Series

ARTICULATING AND
TELESCOPIC BOOM LIFTS



*The Power To Go Where
Others Can't*



The Power to Lift More



*The Power To Maneuver
With Precision Accuracy*

**1200SJP
1250AJP
1350SJP**

www.jlg.com

JLG

Articulating Boom Lifts

Put the Power of the JLG® Ultra Series Boom Lifts to Work For You

The JLG revolutionary Ultra Series boom lifts are engineered with the strength, power and extended reach to take operators to greater heights — with productivity features that put these boom lifts in a class of their own.

The Strength You Need

The Ultra Series booms are built from 100,000 psi steel, making them 40% stronger than the competition and the most robust in the industry. With a dual 1,000/500 lb capacity, the Ultra Series can handle more workers, tools or materials and provide better reach to critical work areas. The boom strength also allows JLG to offer exclusive Workstation in the Sky® packages that increase operator productivity and ease of operation.

The JLG QuikStik® boom design allows the Model 1250AJP to go from full platform elevation to the ground in 95 seconds.



Telescopic Boom Lifts

The Comfort You Expect

Designed with the operator in mind, every JLG Ultra Series boom lift features a control system that adjusts the swing speed to the boom extension to maintain constant platform velocity. Steering speed is proportional to wheel angle to help reduce the jerky motion effect common on competitive boom lifts. Ease of operation is provided as the control system automatically synchronizes the wheels when switching between the three steering modes.

The Ultra Series features an envelope tracking system that regulates speeds at the work envelope edges, lessening machine dynamics to enhance operator comfort.

Envelope

Slowdown Line

Slowdown Zone
(Creep)

Buffer Line

Buffer Zone
(Super Creep)



Articulating Boom Lifts

The JLG Model 1250AJP articulating boom lift delivers the additional reach capabilities only an articulating boom can provide for applications that demand more flexibility. The Model 1250AJP takes you up, over, out and around obstructions and is ideal for applications that require optimum high-reach versatility such as: petrochemical, steel and paper mills, airport construction and aircraft maintenance, stadium/arena/convention centers, co-generation plants, shipyards and bridge renovation and construction.

■ Larger Working Range

With an up-and-over height of 60 ft 6 in. (18.44 m) and horizontal outreach of 63 ft 2 in. (19.25 m), the Model 1250AJP can easily clear five-story buildings and obstructions and get you where you need to work.

■ Faster Cycle Speeds

The exclusive JLG QuikStik® boom design allows the Model 1250AJP platform to be lowered to the ground while the tower boom is fully raised and extended. The operator can go from full elevation of 125 feet (38.1 m) to the ground in 95 seconds. The boom design also links two functions, simultaneously raising and telescoping the tower boom. This improves operation and allows full elevation in less than 130 seconds.

Automatic Platform Leveling

While operating an Ultra Series boom lift, the work platform is automatically leveled in relation to gravitational forces, not the machine chassis, as found on competitive equipment. Platform leveling in relation to gravity provides unmatched operator comfort, especially at 135 feet.



Optimum Maneuverability

Standard 4-wheel steer makes maneuvering around congested job sites a snap. Three steering modes are available: 2-wheel steer, 4-wheel coordinated or crab steering. The Ultra Booms feature the tightest turning radius and an industry-best 1:1 crab steer ratio.



1200SJP

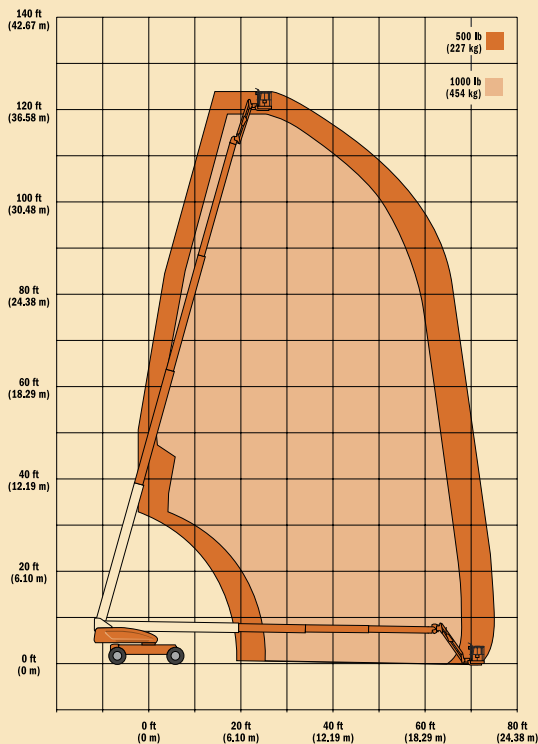

1350SJP

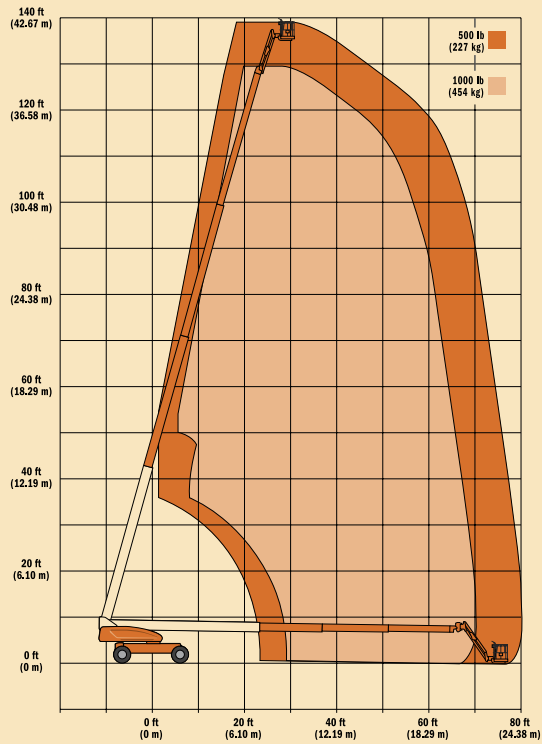

1250AJP

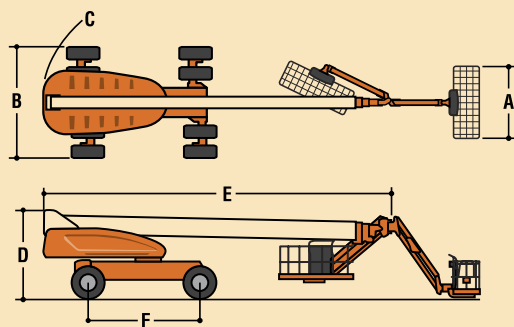
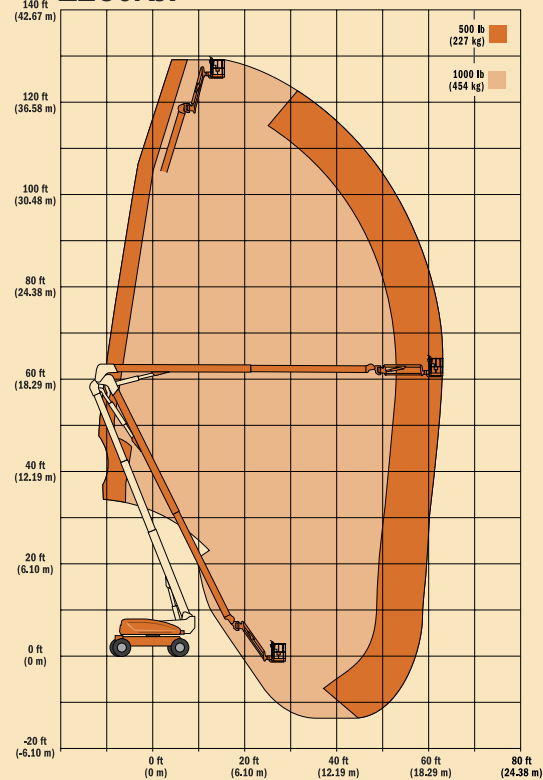

Standard Features

- Platform: 36 x 96 in. (0.91 x 2.44 m)
- Side Entry
- 8 ft (2.44 m) JibPLUS® Boom
- Selectable Capacity Envelope
- Inward Swinging Gate
- 180° Hydraulic Platform Rotator
- AC Receptacle in the Platform
- SkyPower® Package
 - 7500 Watt Generator
 - 240/120V Single Phase
 - 240V 3 Phase
 - 1/2 in. Air Line to Platform
- 5 Degree Tilt Alarm/Indicator Light
- All Motion Alarm
- Swing-Out Engine Tray
- 12V DC Auxiliary Power
- Hourmeter
- Control ADE® System
- Full-time 4WD
- 3 Selectable Steering Modes
- Drive-out Extendible Axles
- Oscillating Axle
- Proportional Controls
- Gull-Wing Hoods
- Operator Tool Tray
- 445/50D710 Foam Filled Rim
- Protector Lug Tread Tires
- Platform Console Machine Status
- Light Panel*
- Lifting/Tie Down Lugs
- Engine Distress Warning/Shutdown—
- Selectable via JLG Analyzer

Individual Options

- Platform: 36 x 72 in. (0.91 x 1.83 m)
- Side Entry
- Fall Arrest Platform
- Light Package¹
- Flashing Beacon
- Soft-Touch System Platform 6 ft/8 ft (1.83 m/2.44 m)
- Exhaust Purifier Muffler
- Cold Weather Start²
- Cold Package Plus³
- Hostile Environment Kit⁴
- Mesh to Top Rail

1. Includes platform mounted work lights and drive/backup lights.
2. Includes glow plugs, battery heater and oil tank heater.
3. Includes arctic hydraulic hoses (drive and steer only) and main boom cable, arctic hydraulic oil, extreme cold engine oil, anti-freeze (CAT only), fuel conditioner, engine block heater, battery blanket, glow plugs, hydraulic tank heater, and oversized footswitch.
4. Includes console cover, boom wipers and cylinder bellows.

Accessory Packages

- SkyWelder®
- SkyCutter®
- SkyGlazier®
- Nite Bright®
- Pipe Racks

*Provides indicator lights at platform control console for system distress, fuel level, low fuel, 5 degree tilt light and foot switch status.

Model 1200SJ

Model 1250AJP

Model 1350SJ

Reach Specifications

Platform Height		120 ft (36.58 m)	125 ft (38.1 m)	135 ft (41.15 m)
Horizontal Reach		75 ft (22.86 m)	63 ft 2 in. (19.25 m)	80 ft (24.38 m)
Up and Over Height		—	60 ft 6 in. (18.44 m)	—
Swing		360° Continuous	360° Continuous	360° Continuous
Platform Capacity—Restricted		1,000 lb (454 kg)	1,000 lb (454 kg)	1,000 lb (454 kg)
Platform Capacity—Unrestricted		500 lb (227 kg)	500 lb (227 kg)	500 lb (227 kg)
Platform Rotator		180°	180°	180°
JibPLUS®	Length	8 ft (2.44 m)	8 ft (2.44 m)	8 ft (2.44 m)
	Horizontal Motion ¹	180°	125°	180°
	Vertical Motion	130° (+75/-55)	130° (+75/-55)	130° (+75/-55)

Dimensional Data

A. Platform Size		36 x 96 in. (0.91 x 2.44 m)	36 x 96 in. (0.91 x 2.44 m)	36 x 96 in. (0.91 x 2.44 m)
B. Overall Width	Axles Retracted	8 ft 2 in. (2.49 m)	8 ft 2 in. (2.49 m)	8 ft 2 in. (2.49 m)
	Axles Extended	12 ft 6 in. (3.81 m)	12 ft 6 in. (3.81 m)	12 ft 6 in. (3.81 m)
C. Tailswing		5 ft 6 in. (1.67 m)	3 ft (91 cm)	5 ft 6 in. (1.67 m)
D. Stowed Height		10 ft (3.05 m)	10 ft (3.05 m)	10 ft (3.05 m)
E. Stowed Length		34 ft 11 in. (10.64 m)	37 ft 7 in. (11.45 m)	38 ft 11 in. (11.86 m)
F. Wheel Base		12 ft 6 in. (3.81 m)	12 ft 6 in. (3.81 m)	12 ft 6 in. (3.81 m)
Ground Clearance	Axle	12 in. (30 cm)	12 in. (30 cm)	12 in. (30 cm)
	Chassis	25.5 in. (65 cm)	25.5 in. (65 cm)	25.5 in. (65 cm)
Gross Vehicle Weight²		40,900 lb (18,552 kg)	44,000 lb (19,958 kg)	45,000 lb (20,411 kg)

Chassis

Max Ground Bearing Pressure*		100 psi (7.03 kg/cm ²)	100 psi (7.03 kg/cm ²)	105 psi (7.38 kg/cm ²)
Drive Speed		3.25 mph (5.2 mph)	3.25 mph (5.2 mph)	3.25 mph (5.2 mph)
Gradeability		45%	45%	45%
Turning Radius (Inside)	Axles Retracted	14 ft 5 in. (4.39 m)	14 ft 5 in. (4.39 m)	14 ft 5 in. (4.39 m)
	Axles Extended	8 ft (2.44 m)	8 ft (2.44 m)	8 ft (2.44 m)
Turning Radius (Outside)	Axles Retracted	22 ft 6 in. (6.86 m)	22 ft 6 in. (6.86 m)	22 ft 6 in. (6.86 m)
	Axles Extended	19 ft 4 in. (5.89 m)	19 ft 4 in. (5.89 m)	19 ft 4 in. (5.89 m)
Crab Steer Ratio³		1:1	1:1	1:1
Axle Oscillation		12 in. (30 cm)	12 in. (30 cm)	12 in. (30 cm)
Tires/Type		445/50D710 Foam Filled	445/50D710 Foam Filled	445/50D710 Foam Filled

Power Source

Diesel Engine	Deutz BF4M 2011	87 hp (65 kW)	87 hp (65 kW)	87 hp (65 kW)
Fuel Tank Capacity		31 gal (117 L)	31 gal (117 L)	31 gal (117 L)
Hydraulic Reservoir		55 gal (208 L)	55 gal (208 L)	55 gal (208 L)
Auxiliary Power		12V DC	12V DC	12V DC
Generator		7500 Watt	7500 Watt	7500 Watt

* Ground bearing pressure applies to standard tires.

1. Capacity is limited to 500 lb (227 kg) when JibPLUS is extended horizontally.

2. Certain options or country standards increase weight.

3. Ratio of forward travel to lateral travel.

Telescopic Boom Lifts

Building on the latest innovations and the most powerful boom arm in the industry, JLG Ultra Series telescopic boom lift models offer you more height, more reach, more capacity, more control and more productivity than any other lift in their class.

■ Unmatched Range of Motion and Reach

With their exclusive controlled arc, the Models 1200SJP and 1350SJP telescopic boom lifts automatically maintain a smooth arc at the edges of the work envelope. The JibPLUS boom feature allows the operator to use the platform to literally reach around corners.* And, with the Capacity Control system, operators can automatically limit the work envelope to a pre-selected zone.

*Capacity is restricted to 500 lb (227kg) when jib is in side-swing mode.

■ More Work with Less Effort

The Model 1200SJP reaches up to 50% more area than other 120-ft (36.58 m) boom lifts, especially in the critical area beyond 50 ft (15.24 m) of reach. It even outreaches the 125-ft (38.1 m) class of boom lifts.

With a comprehensive reach of 135 ft (41.15 m) and a capacity of 1,000 pounds (454 kg), the Model 1350SJP creates a whole new class of telescopic boom lifts. You get an unmatched work envelope and high capacities, plus the power to add productivity-enhancing accessories without compromising reach at critical ranges.

Rough Terrain

Ultra Series Boom Lifts are the ultimate big boom productivity tools with full-time, 4-wheel drive that utilizes two drive pumps—each driving one side of the machine. Two front-to-rear rotary flow dividers provide a level of traction unmatched in this class of boom. Plus, JLG is the only manufacturer to offer an oscillating axle on 120-ft boom lifts and above.



Easier to Transport

No special transport permits required.

All Ultra Series Boom Lifts are transportable on a standard step-deck trailer. The JibPLUS boom can be easily stowed to provide transport lengths under 39 ft (11.89 m). Drive-out extendable axles allow a transport width of 8 ft 2 inches (2.49 m).



Options to Create Your Workstation in the Sky Product

Transform your Ultra Series boom lift into a true Workstation in the Sky product with exclusive options and accessories from JLG. Whether designed for a specific application like the

SkyWelder® Package or to meet a variety of needs like the SkyPower® Package, JLG has many options available to increase your productivity and enhance your work environment.

SkyPOWER

JLG delivers more power where you need it with the SkyPower Package on the Ultra Series boom lifts. The SkyPower package includes a 7500W self-contained generator, plus a power cable and a 1/2 inch air line routed through the boom's power track.

SkyWELDER

Miller® welder is tucked into the SkyPower boom platform. Conserves space and provides stick and TIG capability. Eliminates potentially dangerous leads hanging over the rails and cost of a stand-alone welder.

NiteBRIGHT

The JLG Nite Bright Package consists of six 40W lights—four chassis mounted lights and two platform mounted lights. The Nite Bright Package illuminates your work site plus the area around the chassis for increased visibility.

SkyGLAZIER

The first and only factory-approved glass and panel tray. Utilizes industry-leading JLG capacity to get materials to the work site. Improves productivity and reduces operator fatigue, while protecting panels from damage.

SkyCUTTER

Cut faster and cleaner with an on-board Miller® plasma cutter. Eliminate the dangers of Oxygen/Acetylene tanks and hoses draped over the railings. SkyAir provides the on-board air supply.

Pipe Rack Accessory

The JLG exclusive Pipe Rack Accessory is designed to secure pipes close to where they are needed. The pipe rack is mounted to the top platform rail and can hold up to 180 lb (82 kg) of pipe.

* Miller is a trademark of Miller Electric.



The JLG "1 & 5" Warranty

JLG Industries, Inc. backs its products with its exclusive "1 & 5" Warranty. We provide coverage on all products for one (1) full year, and cover all specified major structural components for five (5) years. Due to continuous product improvements, we reserve the right to make specification and/or equipment changes without prior notification. This machine meets or exceeds applicable OSHA Regulations in 29 CFR 1910.67, 29 CFR 1926.453, ANSI A92.5-2006, and CSA Standard B354.4-02, as originally manufactured for intended applications.

JLG Industries, Inc.

1 JLG Drive
McConnellsburg, PA 17233-9533
Telephone 717-485-5161
Toll-free in US 877-JLG-LIFT
Fax 717-485-6417
www.jlg.com

An Oshkosh Truck Corporation Company

Form No.: SS-Ultra-0505-20M
Part No.: 3131025
R060702
Printed in USA

