

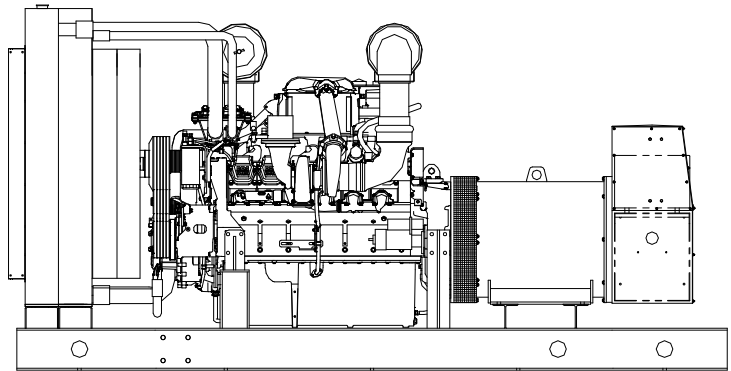

750 ekW 60 Hz Standby
680 ekW 60 Hz Prime
208 - 4160V



- EPA Tier 2 Certified
- Generator Set Tested to ISO 8528-5 for Transient Response
- UL2200, CSA Listing Offered
- Accepts Rated Load in One Step Per NFPA 110, Level 1
- All gen-sets are prototype and factory tested
- MTU DD is a single source supplier
- Global Product Support
- 2 Year Standard Warranty
- Complete Range of Accessories
- Custom Design for any Application

- 12V-2000 G84 Diesel Engine
 - 23.9 Liter Displacement
 - Common Rail Injection
 - 4-Cycle
- Permanent Magnet Generator (PMG)
 - Brushless, Rotating Field
 - 300% Short Circuit Capability
 - 2/3 Pitch Windings
- Digital Control Panel
 - UL 508 Listed, CSA Certified, NFPA 110
 - Complete System Metering
 - LCD Display
- Cooling System
 - Integral Set-mounted
 - Engine Driven Fan

GEN-SET RATINGS

Standby - 130° Rise

Voltage (L-L)	Phase	PF	Hz	kW	kVA	AMPS	skVA @ 30% voltage dip	Generator Model*	Connection
208v	3	0.8	60	750	937.5	2602	2600	574RSL4037	12 LEAD LOW WYE
240v	3	0.8	60	750	937.5	2255	2600	574RSL4037	12 LEAD HI DELTA
480v	3	0.8	60	750	937.5	1128	2150	573RSL4035	12 LEAD HI WYE
600v	3	0.8	60	750	937.5	902	3100	574RSS4278	4 LEAD WYE
4160v	3	0.8	60	750	937.5	130	1850	574FSM4358	6 LEAD WYE

Prime - 105° Rise

Voltage (L-L)	Phase	PF	Hz	kW	kVA	AMPS	skVA @ 30% voltage dip	Generator Model*	Connection
208v	3	0.8	60	680	850	2359	2600	574RSL4037	12 LEAD LOW WYE
240v	3	0.8	60	680	850	2045	2600	574RSL4037	12 LEAD HI DELTA
480v	3	0.8	60	680	850	1022	2150	573RSL4035	12 LEAD HI WYE
600v	3	0.8	60	680	850	818	3100	574RSS4278	4 LEAD WYE
4160v	3	0.8	60	680	850	118	1850	574FSM4358	6 LEAD WYE

The Generator Model Number identified in the table is for standard C Series Configuration. Consult the factory for alternate configuration



STANDARD EQUIPMENT

ENGINE

- Air Cleaners
- Oil Pump
- Full Flow Oil Filter
- Jacket Water Pump
- Inter Cooler Water Pump
- Thermostats
- Exhaust Manifold – dry
- Blower Fan & Fan Drive
- Radiator - Unit Mounted
- Electric Starting Motor - 24V
- Governor – Electric Isochronous
- Base - Structural Steel
- SAE Flywheel & Bell Housing
- Charging Alternator - 24V
- Battery Box & Cables
- Flexible Fuel Connectors
- Flexible Exhaust Connection
- EPA Certified Engine

DIGITAL CONTROL PANEL

- Digital Metering
- Engine Parameters
- Generator Protection Functions
- Engine Protection
- SAE J1939 Engine ECU Communications
- Windows-based Software
- Multilingual Capability
- Remote Communications to our RDP-110 Remote Annunciator
- 16 Programmable Contact Inputs
- 7 contact outputs
- UL Recognized, CSA certified, CE approved
- Event Recording
- IP 54 Front Panel Rating with Integrated Gasket
- NFPA110 Level Compatible

GENERATOR

- NEMA MG1, IEEE and ANSI standards compliance for temperature rise and motor starting
- Sustained short circuit current of up to 300% of the rated current for up to 10 seconds
- Self Ventilated and Drip-proof
- Superior Voltage Waveform
- Digital, Solid State, Volts-per-hertz Regulator
- No Load to Full Load Regulation
- Brushless Alternator with Brushless Pilot Exciter
- 4 pole, Rotating Field
- 130°C Standby Temperature Rise
- 1 Bearing, Sealed
- Flexible Coupling
- Full Amortisseur Windings
- 125% Rotor Balancing
- 3-phase Voltage Sensing
- $\pm .25\%$ Voltage Regulation
- 100% of Rated Load - One Step
- 3% Maximum Harmonic Content



750 kW Diesel Gen-Set

APPLICATION DATA

Engine

Manufacturer: MTU Detroit Diesel	Rated RPM:..... 1800
Model: 12V-2000 G84	Engine Governor:.....ADEC
Type:..... 4-Cycle	Max Power: Standby: bhp (kWm) 1,119 (835)
Arrangement: 12-V	Prime: bhp (kWm) 1,020 (761)
Displacement: in. ³ (lit) 1,458 (23.9)	Speed Regulation: ±.25%
Bore: in. (cm) 5.1 (13.0)	Frequency: 60 Hz
Stroke: in. (cm) 5.9 (15.0)	Air Cleaner:.....Dry
Compression Ratio:..... 16.0:1	

Liquid Capacity (Lubrication)

Total oil system: gal (lit)20.3 (77)
Engine Jacket water capacity: gal (lit)29.1 (110)
After Cooler water capacity: gal (lit)5.3 (20)
System Coolant capacity: gal (lit).....91.1 (345)

Electrical

Electric volts DC:24
Cold cranking Amps under 0°F (-17.8°C):.....1750

Fuel System

Fuel Supply Connection Size:..... ³ / ₄ " NPT
Fuel Return Connection Size: ¹ / ₄ " NPT
Maximum Fuel Lift: ft (m) 10 (3)
Recommended Fuel:.....Diesel #2
Total Fuel Flow: gal/hr (lit/hr)127 (480)

Fuel Consumption

	Standby	Prime
100% Power Rating: gal/hr (lit/hr).....	52.4 (198).....	48.9 (182)
75% Power Rating: gal/hr (lit/hr).....	41.0 (155).....	37.7 (143)
50% Power Rating: gal/hr (lit/hr).....	27.7 (105).....	25.4 (98)

Cooling - Radiator System

	Standby	Prime
Ambient Capacity of Radiator: °F (°C) 104 (40) 104 (40)		
Maximum Allowable Static Pressure on Radiator Exhaust: in. H ₂ O (kPa).....0.5 (0.12) 0.5 (0.12)		
Water Pump Capacity: gal/min (lit/min) 220 (833) 220 (833)		
After Cooler Pump Capacity: gal/min (lit/min) 68 (258) 68 (258)		
Heat Rejection to Coolant: BTUM (kW) 18,767 (330) ... 17,060 (300)		
Heat Rejection to After Cooler: BTUM (kW)..... 12,227 (215) ... 11,098 (195)		
Heat Radiated to Ambient: BTUM (kW).....4,663 (82) 4,265 (75)		

Air Requirements

	Standby	Prime
Aspirating: CFM (m ³ min) 2,225 (63)..... 2,119 (60)		
Air Flow Required for Radiator Cooled Unit: CFM (m ³ min) 38,223 (1,082) 38,223 (1,082)		
Air Flow Required for Heat Exchanger/ Remote Radiator based on 25°F Rise: CFM (m ³ min)..... 10,362 (294)..... 9,478 (268)		

Exhaust System

	Standby	Prime
Gas Temp.(Stack) °F (°C)..... 1,040 (560)..... 1,022 (550)		
Gas Volume at Stack Temp: CFM (m ³ min)..... 5,297 (150)..... 5,085 (144)		
Maximum Allowable Back Pressure: in. H ₂ O (kPa) 34.1 (8.5) 34.1 (8.5)		



750 kW Diesel Gen-Set

EMISSIONS DATA

<u>NOx + NMHC</u>	<u>CO</u>	<u>PM</u>
4.03.....	0.81	0.09

All units are in g/hp-hr and are EPA D2 cycle values.

Emission levels of the engine may vary as a function of ambient temperature, barometric pressure, humidity, fuel type and quality, installation parameters, measuring instrumentation, etc. The data provided are laboratory results from one engine representing this rating. The data was obtained under controlled environmental conditions with calibrated instrumentation traceable to the United States National Bureau of Standards and in compliance with US EPA regulations found within 40 CFR Part 89. The weighted cycle value from each engine is guaranteed to be below the US EPA Standards at the US EPA defined conditions.

SOUND DATA

	<u>Standby Full Load</u>	<u>Standby No Load</u>	<u>Prime Full Load</u>	<u>Prime No Load</u>
23 ft (7m) OPU w/ critical grade muffler: (dBA)	100	93	98.5	93
23 ft (7m) Sound Attenuated Enclosure: (dBA)	92	85	90.5	85

RATING DEFINITIONS and CONDITIONS

- Ambient capability factor at 300m (984 ft). Consult your local MTU DD Power Generation Distributor for other altitudes.
- Standby ratings apply to installations served by a reliable utility source. The standby rating is applicable to varying loads for the duration of a power outage. No overload capability for this rating. Ratings are in accordance with ISO-3046/1, BS 5514, AS 2789, and DIN 6271.
- Prime power ratings apply to installations where utility power is unavailable or unreliable. At varying load, the number of generator set operating hours is unlimited. A 10% overload capacity is available for one hour in twelve. Ratings are in accordance with ISO-8528/1, overload power in accordance with ISO-3046/1, BS 5514, AS 2789, and DIN 6271. For limited running time and base load ratings, consult the factory.
- Deration Factors:
 Altitude: No power decrease with increased elevation up to 5,906 ft. (1,800m)* at 77°F (25°C).
 Temperature: Derate 2.5% per 9°F (5°C) over 122°F (50°C) at 328 ft (100m).
 *Contact factory for deration above 5,906 ft. (1,800m).

Weights & Dimensions

Length: in. (cm).....	170 (432)
Width: in. (cm).....	63 (160)
Height: in. (cm).....	86.5 (220)
Weight (dry): lb. (kg).....	12,108 (5,492)

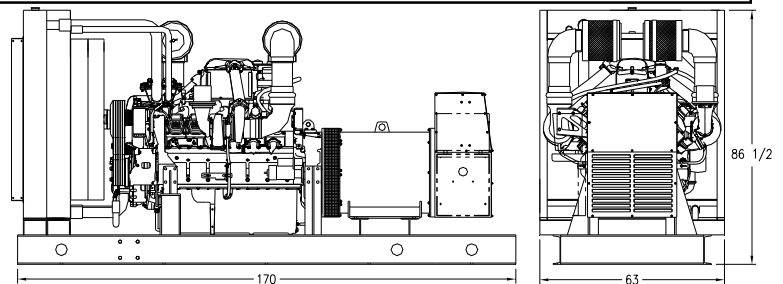

Drawing above for illustration purposes only, based on standard open power 480 volt generator. Lengths may vary with other voltages.
*Do Not Use for Installation Design

DISTRIBUTED BY:

Materials and specifications subject to change without notice.
© MTU DD Power Generation. A Tognum Group Company.
100 Power Drive, Mankato, MN 56001
Phone: 800-325-5450
www.mtuddpowergeneration.com