



DCA25USI

Ultra-Silent Series

WhisperWatt™ 25

Prime Rating: 20 kW (25 kVA)

Standby Rating: 22 kW (27.5kVA)

60 Hertz

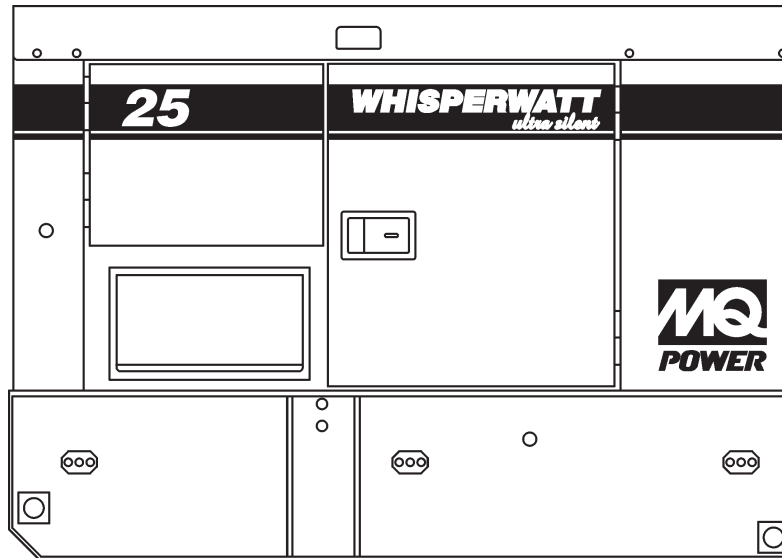

Standard Features

- **Heavy duty, 4-cycle, direct injection diesel engine** provides maximum reliability.
- **Brushless alternator** reduces service and maintenance requirements and meets temperature rise standards for Class F insulation systems.
- **Open delta alternator design** provides virtually unlimited excitation for maximum motor starting capability.
- **Automatic voltage regulator (AVR)** provides precise regulation.
- **Full load acceptance** of standby nameplate rating in one step (NFPA 110, para 5-13.2.6).
- **Sound attenuated, weather resistant, steel housing** provides ultra-silent operation at 56 dB(A) at 23 feet. Fully lockable enclosure allows safe unattended operation.
- **Integrated fuel tank** with direct reading fuel gauges.
- **Seven-stage powder coat paint** provides durability and weather protection.
- **Fuel/water separator** removes condensation from fuel for extended engine life. Panel mounted alarm light included.
- **Complete engine analog instrumentation** includes DC ammeter, oil pressure gauge, water temp. gauge, fuel level gauge, tachometer/hour meter, preheat indicator, emergency shutdown monitors, and keyed start switch.
- **Complete generator analog instrumentation** includes voltage regulator control, ammeter phase selector switch, voltmeter phase selector switch, AC voltmeter, AC ammeter, frequency meter, panel light, and circuit breaker.
- **Automatic safety shutdown system** monitors the engine oil pressure and water temperature. Warning lights indicate abnormal conditions.
- **Complete power panel.** Fully covered; three-phase terminals and single phase receptacles allow fast and convenient hookup for most applications including temporary power boxes, tools and lighting equipment. All are NEMA standard.
- **Simultaneous single and three phase power.**
- **Voltage selector switch** allows easy to change voltages as your applications require.
- **EPA emissions certified** - Tier 2 emissions compliant.



DCA25USI

Ultra-Silent Series

Specifications

Generator Specifications

Design	Revolving field, self-ventilated Drip-proof, single bearing
No. of Poles	4-pole
Excitation	Brushless with AVR
Standby Output	22 KW (27.5 KVA)
Prime Output	20 KW (25 KVA)
Generator RPM	1800
Voltage — 3Ø	208, 220, 240, 416, 440, 480V Switchable
Voltage — 1Ø	120, 127, 139, 240, 254, 277V Switchable
Armature Connection	Star with neutral / Zig Zag
Voltage Regulation (No load to full load)	±1.0%
Power Factor	0.8
Frequency	60 Hz
Frequency Regulation: No Load to Full Load	3~5% under varying loads from no load to 100% rated load
Frequency Regulation: Steady State	±0.5% of mean value for constant loads from no load to full load.
Insulation	Class F
Sound Level dB(A) Full load at 23 feet	56

Engine Specifications

Make / Model	Isuzu / AA-4LE2
Emissions	EPA Tier 2 Certified
Starting System	Electric
Design	4-cycle, water cooled, direct injection
Displacement	133.0 in ³ (2179 cc)
No. cylinders	4
Bore x Stroke (mm)	85 x 96
Gross Engine Power Output	35.9 bhp (26.8 kWm)
BMEP	104 psi (719 kPa)
Piston Speed	1134 ft./min. (5.76 m/s)
Compression Ratio	18:1
Engine Speed	1800 rpm
Overspeed Limit	2100 rpm
Oil Capacity	2.25 gallons (8.5 liters)
Battery	12V 53Ah x 1

Fuel System

Maximum Fuel Flow (per hour)	3.7 gallons (14 liters)	
Maximum Inlet Restriction (Hg)	1.18 in. (30 mm)	
Fuel Tank Capacity	41.7 gallons (158 liters)	
Fuel Consumption	gph	lph
At full load	1.44	5.47
At 3/4 load	1.05	3.99
At 1/2 load	0.74	2.81
At 1/4 load	0.45	1.70

Cooling System

Fan Load	0.67 hp (0.5 kW)
Coolant Capacity (with radiator)	1.7 gallons (6.4 liters)
Coolant Flow Rate (per minute)	15.6 gallons (59 liters)
Heat Rejection to Coolant (per minute)	1155 Btu (1.22 MJ)
Heat Radiated to Room (per minute)	123.2 Btu (0.13 MJ)
Maximum Coolant Friction Head	6.4 psi (44.1 kPa)
Maximum Coolant Static Head	7.2 feet (2.2 meters)
Ambient Temperature Rating	104°F (40°C)

Air

Combustion Air	58.6 cfm (1.67 m ³ /min)
Maximum Air Cleaner Restriction	25.0 in. H ₂ O (6.2 kPa)
Alternator Cooling Air	388 cfm (11 m ³ /min)
Radiator Cooling Air	1059 cfm (30 m ³ /min)

Exhaust System

Gas Flow (full load)	144 cfm (4.08 m ³ /min)
Gas Temperature	1058°F (570°C)
Maximum Back Pressure	67.2 in. H ₂ O (16.7 kPa)

Amperage

Rated Voltage	Maximum Amps
1Ø 120 Volt	55.5 Amps (4 wire)
1Ø 240 Volt	27.8 Amps (4 wire)
3Ø 240 Volt	60 Amps
3Ø 480 Volt	30 Amps
Main Line Circuit Breaker Rating	60 Amps
Over Current Relay Trip Set Point	30 Amps

Warranty*

Isuzu Engine

12 months from date of purchase with unlimited hours or 24 months from date of purchase with 2000 hours (whichever occurs first).

Generator

24 months from date of purchase or 2000 hours (whichever occurs first).

Trailer

12 months excluding normal wear items.

*Refer to the express written, one-year limited warranty sheet for additional information.

Generator is not intended for use in enclosed areas or where free flow of air is restricted. Backfeed to a utility system can cause electrocution and/or property damage. Do not connect to any building's electrical system except through an approved device.

Specifications are subject to change without notice.



DCA25USI

Ultra-Silent Series

MQ POWER DECIBEL LEVELS

Our soundproof housing allows substantially lower operating noise levels than competitive designs. Ultra-Silent are at home on construction sites, in residential neighborhoods, and at hospitals — just about anywhere.

- 90 — Subway / truck traffic
- 80 — Average city traffic
- 70 — Inside car at 60 mph
- 60 — Air conditioner at 20 feet
- Ultra-Silent at 23 feet
- 50 — Normal conversation



Ultra-Silent Features

- Low Noise Muffler**— Large capacity low noise muffler minimizes exhaust sound.
- Soundproof Casing**— The new design divides the cabinet into three sections, separating the engine, muffler and radiator for more efficient cooling and reduces noise from the engine and fans.
- New Cooling System**— An advanced design uses two separate air intake systems to cool the generator. The engine fan draws air in to cool the engine and generator housing while a second electric fan directly cools the radiator. With less air being drawn into the generator through each fan, considerably less noise is produced through the top of the generator.
- Environmental Design** — Constructed using an integrated environmental skid and fuel tank. This design fully contains fuel leakage and any liquid that might leak from the engine such as lube oil or radiator coolant. All potentially hazardous liquids are contained without contaminating the surrounding area.

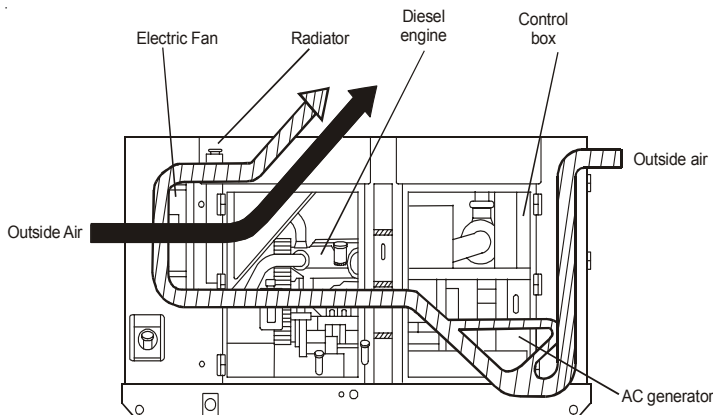

Flow of Cooling Air

Generator Output Panel

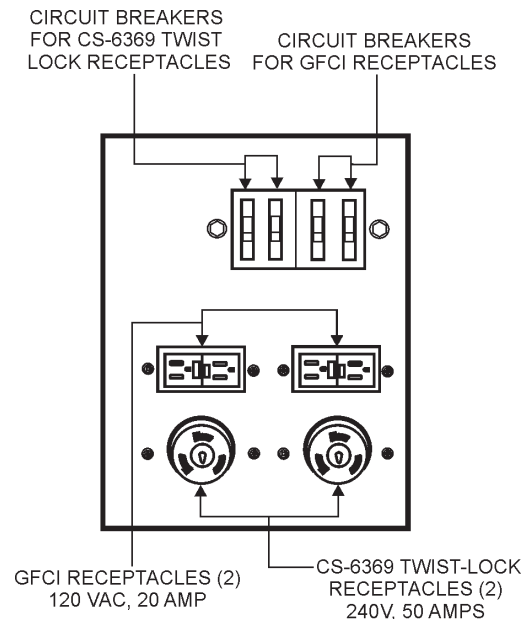

Optional Control Features

- Emergency Stop Switch.**
- Audible Alarm** — alerts operator of abnormal conditions.
- Automatic Start / Stop Control** — automatically starts the generator set during a commercial power failure when used in conjunction with a transfer switch.

Optional Generator Features

- Electronic Governor Control (Crystal Sync)** — maintains frequency to within $\pm 0.25\%$ from no load to full load.
- Battery Charger** — provides fully automatic and self-adjusting charging to the generator's battery system.
- Jacket Water Heater** — for easy starting in cold weather climates.
- Special Batteries** — long life batteries provide extra engine cranking power.
- Spring Isolators** — provides extra vibration protection for standby applications.
- Low Coolant Level Shutdown** — provides protection from critically low coolant levels. Includes control panel warning light.
- Trailer Mounted Package** — highway legal trailer with electronic or surge brakes with single or tandem axle configuration.

Optional Distribution Devices

- Pin & Sleeve Connectors.**
- AC Output Cable.**



DCA25USI

Ultra-Silent Series

Dimensions

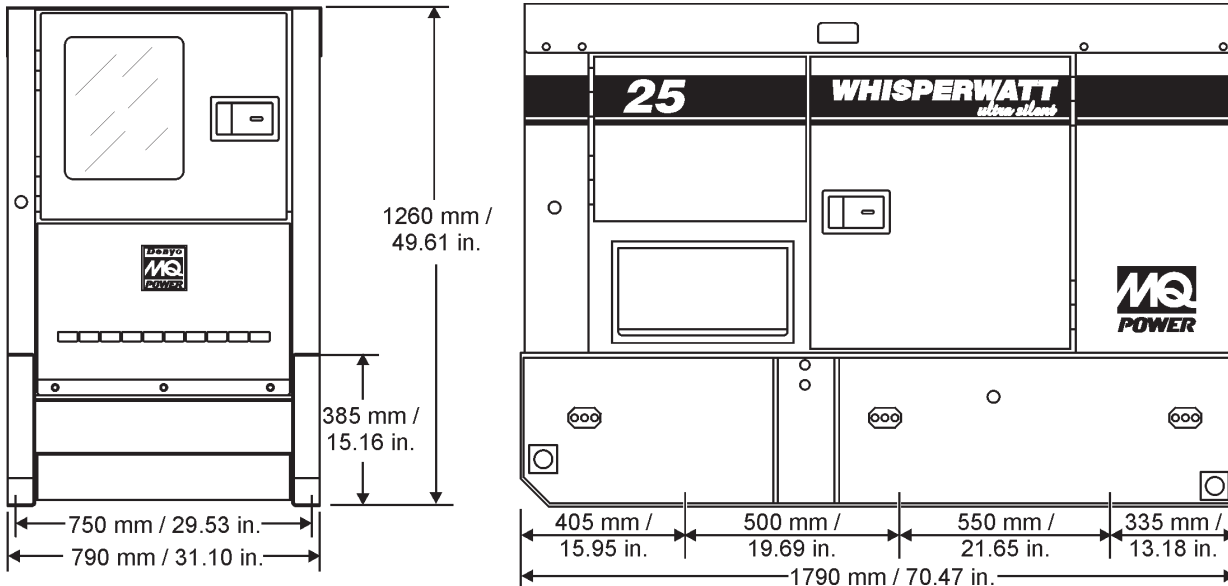

Weight

Dry Weight	1808 lbs. (820 kg)
Wet Weight	2138 lbs. (970 kg)

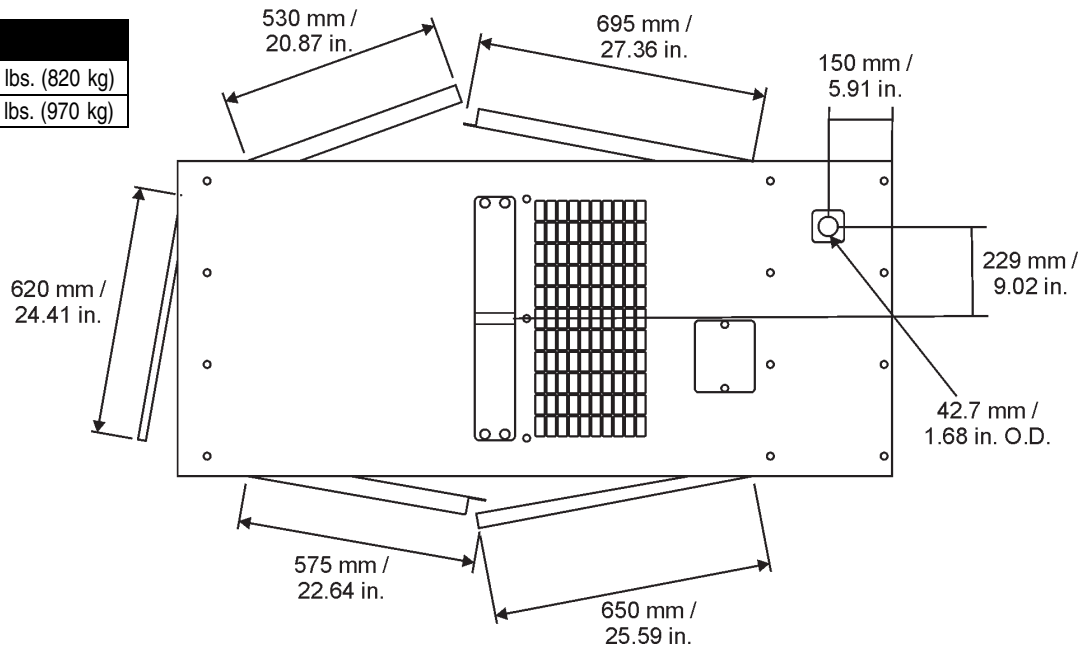

Units manufactured by Denyo Corp.

Your MQ Power dealer is:



MQ POWER
 POST OFFICE BOX 6254
 CARSON, CA 90749
 310-537-3700 • 800-883-2551
 FAX: 310-632-2656
 E-MAIL: mqpower@multiquip.com
 WEBSITE: www.mqpower.com