



DCA300SSK

WhisperWatt™ Generator

WhisperWatt™ 300

Prime Rating: 240 kW (300kVA)

Standby Rating: 264 kW (330 kVA)

60 Hertz

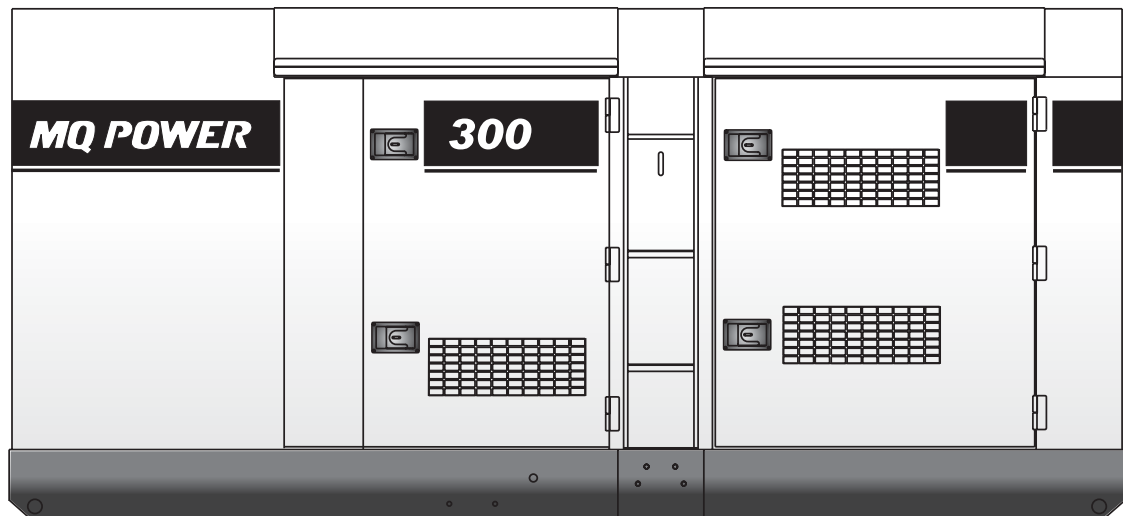

Standard Features

- **Heavy duty, turbocharged, direct injection diesel engine** provides maximum reliability.
- **Brushless alternator** reduces service and maintenance requirements and meets temperature rise standards for Class F insulation systems.
- **Open delta alternator design** provides virtually unlimited excitation for maximum motor starting capability.
- **Automatic voltage regulator (AVR)** provides precise regulation.
- **Electronic governor system** maintains frequency to $\pm 0.25\%$.
- **Full load acceptance** of standby nameplate rating in one step (NFPA 110, para 5-13.2.6).
- **Sound attenuated, weather resistant, steel housing** provides operation at 72 dB(A) at 23 feet. Fully lockable enclosure allows safe unattended operation.
- **Internal fuel tank** with direct reading fuel gauges are standard.
- **E-Coat primer** with polyurethane enamel finish coat.
- **Low coolant level shutdown system** provides protection from critically low coolant levels. Includes control panel warning light.
- **Complete engine analog instrumentation** includes DC ammeter, oil pressure gauge, water temp. gauge, tachometer/hour meter, preheat indicator, manual engine speed control, emergency shutdown monitors, and emergency stop button.
- **Complete generator analog instrumentation** includes voltage regulator control, ammeter phase selector switch, voltmeter phase selector switch, AC voltmeter, AC ammeter, frequency meter, panel light, and circuit breaker.
- **Automatic safety shutdown system** monitors the water temperature, engine oil pressure, overspeed, and overcrank. Warning lights indicate abnormal conditions.
- **Auto start/stop control** allows generator to start automatically in the event of a commercial power failure.
- **Complete power panel.** Fully covered; three-phase terminals and single phase receptacles allow fast and convenient hookup for most applications including temporary power boxes, tools and lighting equipment. All are NEMA standard.
- **Simultaneous single and three phase power.**
- **Emergency stop switch.**
- **Battery switch**
- **EPA emissions certified.** - Tier 3 emissions compliant.



DCA300SSK

WhisperWatt™ Generator

Specifications

Generator Specifications	
Design	Revolving field, Self-ventilated Drip-proof, Single bearing
No. of Poles	4-pole
Excitation	Brushless with AVR
Standby Output	264 KW (330 KVA)
Prime Output	240 KW (300 KVA)
Generator RPM	1800
Voltage — 3Ø	208, 220, 240, 416, 440, 480V Reconnectable
Voltage — 1Ø	120, 127, 139, 240, 254, 277V Adjustable
Armature Connection	Star with neutral
Voltage Regulation (No load to full load)	±0.5%
Power Factor	0.8
Frequency	60 Hz
Insulation	Class F
Sound Level dB(A) Full load at 23 ft	72

Engine Specifications	
Make/Model	Komatsu/SAA6D125E-5
Emissions	EPA Tier 3 Certified
Starting System	Electric
Design	4-cycle water cooled, Direct injection, turbocharged, air-to-air intercooled
Displacement	11044cc
No. cylinders	6
Bore x Stroke (mm)	125 x 150
Gross Engine Power Output	420 hp (313 kW)
BMEP	238 psi (1640 kPa)
Piston Speed	1772 ft/min (9.0 m/s)
Compression Ratio	16.7 : 1
Engine Speed	1800 rpm
Overspeed Limit	2070 rpm
Oil capacity gallons (liters)	16.6 (63)
Battery	150 Ah x 2 (24V systems)

Fuel System	
Recommended Fuel	ASTM-D975-No.1 & No. 2-D
Maximum Fuel Flow (per hour)	81.9 gal (310 L)
Maximum Inlet Restriction (Hg)	11.3 in. (287 mm)
Fuel Tank Capacity	129 gal (490 L)
Fuel Consumption	
full load gph (lph)	16.7 (63.1)
75% load gph (lph)	12.4 (46.8)
50% load gph (lph)	8.8 (33.5)
25% load gph (lph)	5.2 (19.8)

Cooling System	
Fan Load	17.8 hp (13.2 kW)
Coolant Capacity (with radiator)	12.2 gal (46.1 L)
Coolant Flow Rate	87.2 gal (330 L)
Heat Rejection to Coolant	7606 Btu (8.0 MJ)
Heat Radiated from Engine	2838 Btu (3.0 MJ)
Maximum Coolant Friction Head	5.0 psi (35 kPa)
Maximum Coolant Static Head	26 ft. (8.0 m)
Ambient Temperature Rating	104°F (40°C)

Air	
Combustion Air	706 cfm (20m³/min)
Maximum Air Cleaner Restriction	30 in. H2O (7.5 kPa)
Alternator Cooling Air	2797 cfm (79.0 m³/min)
Radiator Cooling Air	9323 cfm (264 m³/min)

Exhaust System	
Gas Flow (full load)	748 cfm (21.2 m³/min)
Gas Temperature	860°F (460°C)
Maximum Back Pressure	56 in. H2O (14 kPa)

Amperage		
	Rated Voltage	Maximum Amps
	1Ø 120 Volt	666.7 Amps (4 wire)
	1Ø 240 Volt	333.3 Amps (4 wire)
	3Ø 240 Volt	722 Amps
	3Ø 480 Volt	361 Amps
	Main Line Circuit Breaker Rating	800 Amps
	Over Current Relay Trip Set Point	360 Amps

Warranty*

Komatsu Engine

12 months from date of purchase or 1000 hours (whichever occurs first).

Generator

24 months from date of purchase or 2000 hours (whichever occurs first).

Trailer

12 months excluding normal wear items.

*Refer to the express written, one-year limited warranty sheet for additional information.

Generator is not intended for use in enclosed areas or where free flow of air is restricted. Backfeed to a utility system can cause electrocution and/or property damage. Do not connect to any building's electrical system except through an approved device.

Specifications are subject to change without notice.



DCA300SSK WhisperWatt™ Generator

MQ POWER DECIBEL LEVELS

Our soundproof housing allows substantially lower operating noise levels than competitive designs. WhisperWatts are at home on construction sites, in residential neighborhoods, and at hospitals — just about anywhere.

- 90 — Subway / truck traffic
- 80 — Average city traffic
- 72.0 — **WhisperWatt at 23 feet**
- 70 — Inside car at 60 mph
- 60 — Air conditioner at 20 feet
- 50 — Normal conversation



Generator Output Panels

CIRCUIT BREAKERS
TWIST LOCK AND GFCI
RECEPTACLES

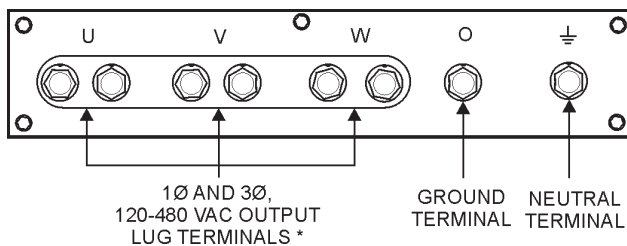
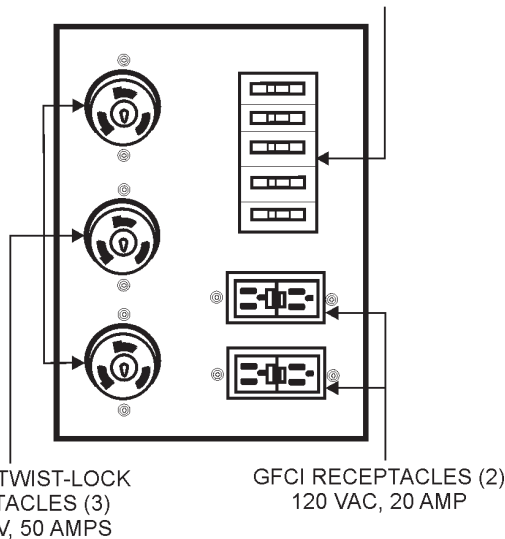

Optional Generator Features

- Battery charger** — provides fully automatic and self-adjusting charging to the generator's battery system.
- Jacket water heater** — for easy starting in cold weather climates.
- Special batteries** — long life batteries provide extra engine cranking power.
- Spring Isolators** — provides extra vibration protection for standby applications.
- Fuel / water separators** — removes condensation from fuel for extended engine life.
- Trailer mounted package** — highway legal trailer with electric or surge brakes with triple axle configuration. Extra capacity fuel tanks are also available.

Optional Control Features

- Remote speed adjust rheostat** — allows for engine speed adjustment from the control panel.
- Audible alarm** — alerts operator of abnormal conditions.

Optional Fuel Cell Features

- Trailer fuel tank** — a second fuel cell located in the trailer allows for extended run time.
- Subbase fuel cells (double wall)** — Additional fuel cell for extended runtime operation. Contains a leak sensor, low fuel level switch, and a secondary containment tank. UL142 listed.
 - 12 hours of minimum run time.
 - 24 hours of minimum run time.

Optional Output Connections

- Cam-Loks** — provides quick disconnect alternative to bolt-on connections.
- Pin and Sleeve connectors** — provides industry standard connectors for all voltage requirements.
- Output cable** — available in any custom length and size configuration.



DCA300SSK

WhisperWatt™ Generator

Dimensions

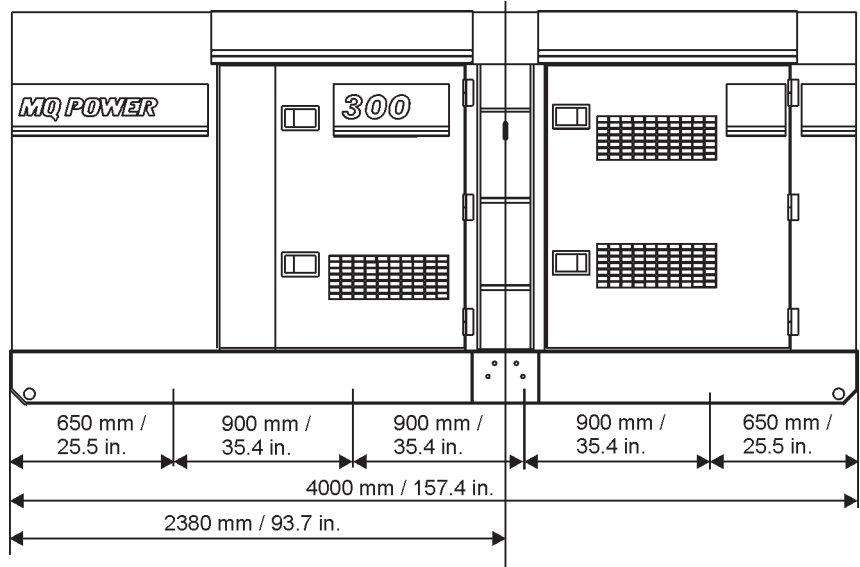
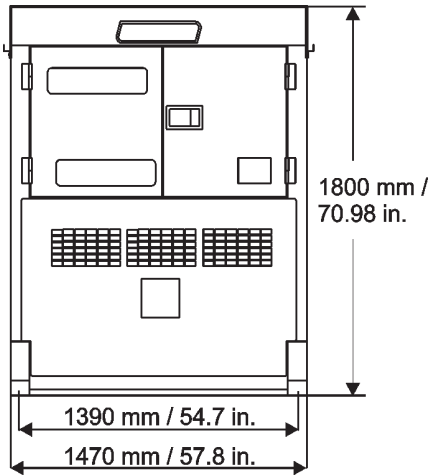

Weight

Dry Weight	10,165 lbs (4610 kg)
Wet Weight	11,356 lbs (5150 kg)

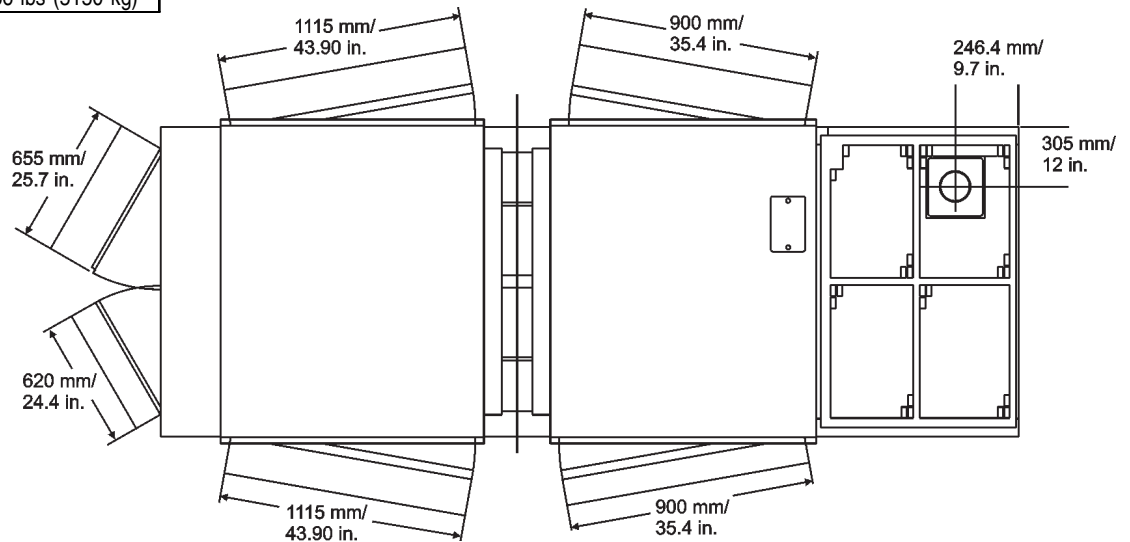

Units manufactured by Denyo Corp.

Your MQ Power dealer is:



MQ POWER
 POST OFFICE BOX 6254
 CARSON, CA 90749
 310-537-3700 • 800-421-1244
 FAX: 310-632-2656
 E-MAIL: mq@multiquip.com
 WEBSITE: www.mqpower.com