

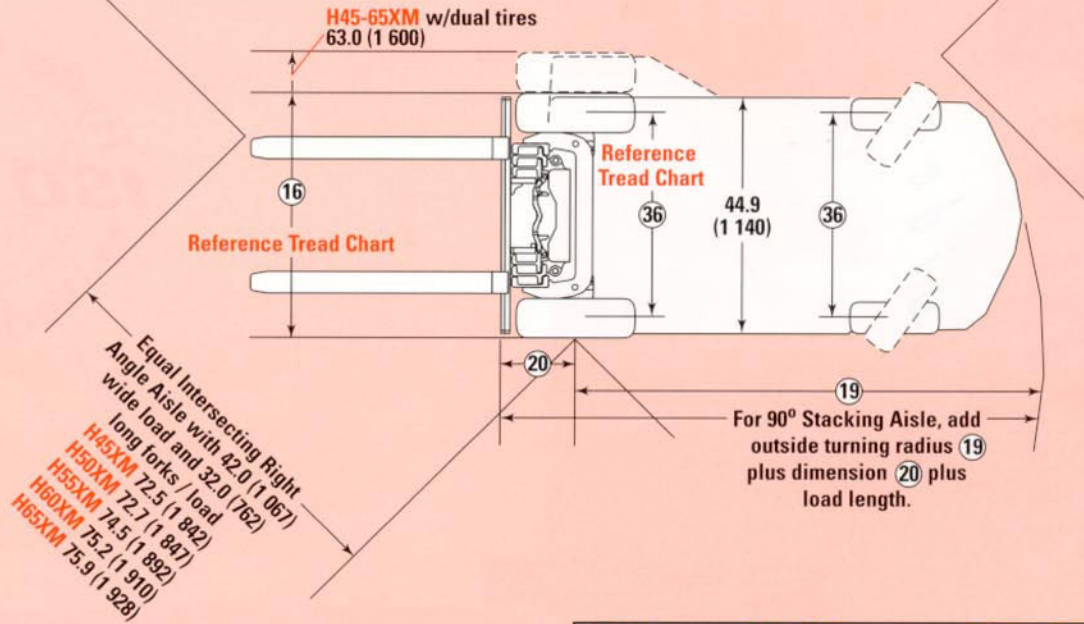

Hyster H45-65XM Lift Truck Specifications



MODEL	MAST	A in. (mm)	B in. (mm)	C in. (mm)	D %	E Deg.
H45XM	ALL	18.5 (470)	31.2 (793)	27.4 (696)	36%	26°
H50XM	ALL	18.5 (470)	33.7 (856)	27.4 (696)	31%	26°
H55XM	ALL	18.5 (470)	36.0 (914)	28.0 (711)	30%	28°
H60XM	ALL	18.8 (478)	37.1 (942)	28.0 (711)	28%	28°
H65XM	ALL	18.8 (478)	37.1 (942)	28.0 (711)	31%	27°

Model	Tread Size	Tread Width
H45-50XM	Standard 7.00-12, 12 Ply	45.5 (1 156)
H55-65XM	Standard 28 x 9-15, 12 Ply	47.2 (1 199)
H45-50XM	Wide 7.00-12, 12 Ply	52.0 (1 321)
H55-65XM	Wide 28 x 9-15, 12 Ply	52.6 (1 336)

MODEL	CAPACITY lb. (kg)	LOAD CENTER in. (mm)	MOMENT in-lb (cm-kg)
H45XM	4,500 (2 041)	24 (610)	191,250 (218 250)
H50XM	5,000 (2 268)	24 (610)	212,500 (242 500)
H55XM	5,500 (2 495)	24 (610)	233,750 (242 500)
H60XM	6,000 (2 722)	24 (610)	256,800 (294 000)
H65XM †	6,500 (2 948)	24 (610)	278,200 (313 600)

† With 126.5" (3 215 mm) or lower 2-stage limited free-lift VISTA® mast.

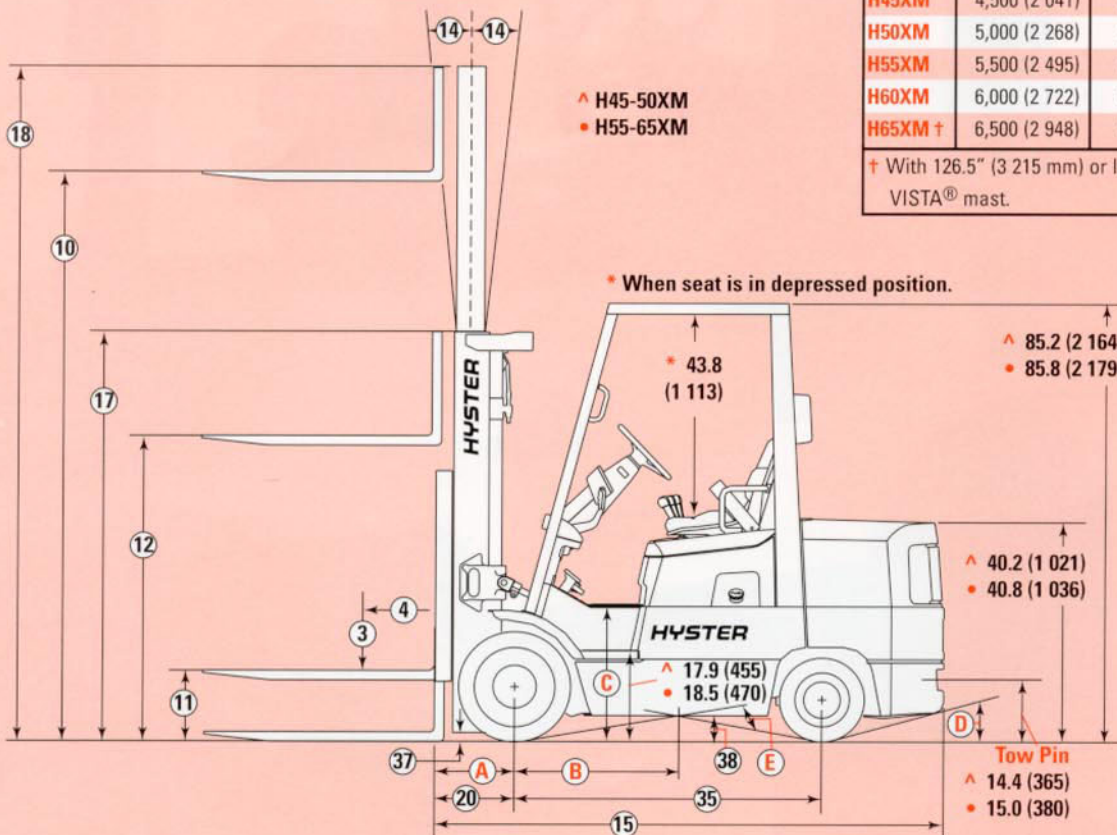

Circled dimensions correspond to the line numbers on the tabulated chart inside the Technical Guide.
Dimensions are in inches (millimeters).



Hyster H60XM Lift Truck Specifications

GENERAL	1	Manufacturer	Hyster Company
	2	Model	H60XM (Mazda 2.0L)
	3	Capacity, rated	lb. (kg) 6,000 (2 722)
	4	Load center	in. (mm) 24 (610)
	5	Power type	Gas / LPG
	6	Operator type	Sit
	7	Tire type, front / rear	Pneumatic / Pneumatic
	8	Wheels, front / rear	(X=driven) 2X / 2
DIMENSIONS	10	2-stage LFL (TOF)	in. (mm) 131.0 (3 327)
	11	Limited free-lift (TOF)	in. (mm) 5.5 (140)
	12	Optional full free-lift (TOF) with / without LBE	in. (mm) 38.4 (975) / 59.0 (1 499)
	13	Forks, width / thickness	in. (mm) 5.0 (127) / 2.0 (51)
	14	Tilt angle, standard mast, forward / backward	Deg.° 6 / 6
	15	Length to face of forks	in. (mm) 104.9 (2 665)
	16	Width, standard tires	in. (mm) 47.4 (1 204)
	17	Height, standard mast lowered	in. (mm) 86.5 (2 197)
	18	Height, std. mast extended with / without LBE	in. (mm) 174.9 (4 442) / 153.7 (3 904)
	19	Turning radius, minimum outside	in. (mm) 90.6 (2 301)
PERFORMANCE †	20	Length, center drive axle to face of forks	in. (mm) 18.8 (478)
	22	Aisle width	in. (mm) 109.5 (2 781)
		Right angle stacking aisle (40 x 48 pallet)	in. (mm) 157.4 (3 998)
	23	Stability (Comply with ANSI?) *	Yes
	24	Travel speed, max. forward, Gas / LPG, RL	mph (km/h) 11.7 (18.8) / 11.7 (18.8)
	25	Lift speed, std LFL mast NL / RL	ft/min (m/s) 104.0 (0.53) / 90.0 (0.46)
		Opt. 2-stage FFL NL / RL	ft/min (m/s) 102.0 (0.52) / 89.0 (0.45)
		Opt. 3-stage FFL NL / RL	ft/min (m/s) 100.0 (0.51) / 88.0 (0.45)
26	Lowering, std LFL mast NL / RL	ft/min (m/s) 83.0 (0.42) / 99.0 (0.50)	
	Opt. 2-stage FFL NL / RL	ft/min (m/s) 83.0 (0.42) / 99.0 (0.50)	
	Opt. 3-stage FFL NL / RL	ft/min (m/s) 83.0 (0.42) / 99.0 (0.50)	
	27	Drawbar pull, powershift, 1 mph NL / RL	lb _f . (kN) 2,949 (13.1) / 3,030 (13.5)
		LPG data (this line only) NL / RL	lb _f . (kN) 2,949 (13.1) / 3,030 (13.5)
28	Gradeability, powershift, 1 mph NL / RL	% 27 / 19	
		LPG data (this line only)	% 27 / 19
WT.	30	Total approximate weight, std equipped truck	lb. (kg) 9,495 (4 307)
	31	Axle loading, static, front / rear - RL	lb. (kg) 13,809 (6 264) / 1,815 (823)
WHEELS & TIRES	32	Number tires front / rear	2 / 2
	33	Size of drive tires, front	28 x 9 - 15 - 12 Ply
	34	Size of steer tires, rear	6.50 x 10 - 10 Ply
	35	Wheelbase	in. (mm) 63.9 (1 623)
	36	Tread, center of tires, steer / drive	in. (mm) 38.2 (970) / 38.1 (968)
	37	Ground clearance, lowest point - NL	in. (mm) 6.2 (158)
	38	Ground clearance, center wheelbase - NL	in. (mm) 6.9 (175)
	39	Brakes, method of control, service / parking	Hydraulic / Mechanical
	40	Brakes, method of operation, service / parking	Foot / Hand
	DRIVETRAIN	42	Battery, volts / cold cranking amps
46		Engine, make-model	Mazda 2.0L
47		Output per SAE standards, Gas / LPG	hp (kW) 42.0 (31) / 42.0 (31)
48		Governed speed NL	RPM 2,800
49		Cycle / number of cylinders / displacement cu.in. (cm ³)	4 / 4 / 122.0 (1 999)
51		Clutch type, powershift	Torque Converter
52		Gear change type, powershift	Monotrol Pedal
53		Number of speeds, forward / reverse	1 / 1
54		Transmission type	Powershift
55		Relief pressure for attachments	psi (kPa) 2,250 (15 513)

* **CERTIFICATION:** These Hyster lift trucks meet design specifications of Part II ANSI B56.1-1969, as required by OSHA Section 1910.178 (a) (2) and comply with Part III ANSI B56.1-revision in effect at time of manufacture. Certification of compliance with the applicable ANSI standards appears on the lift truck's nameplate which is affixed to truck when shipped complete from the factory.

† For lifting information on H45-65XM LPG powered trucks. Refer to [Performance Specifications Chart](#) located on the Mast Dimensions and Performance Specifications page.