

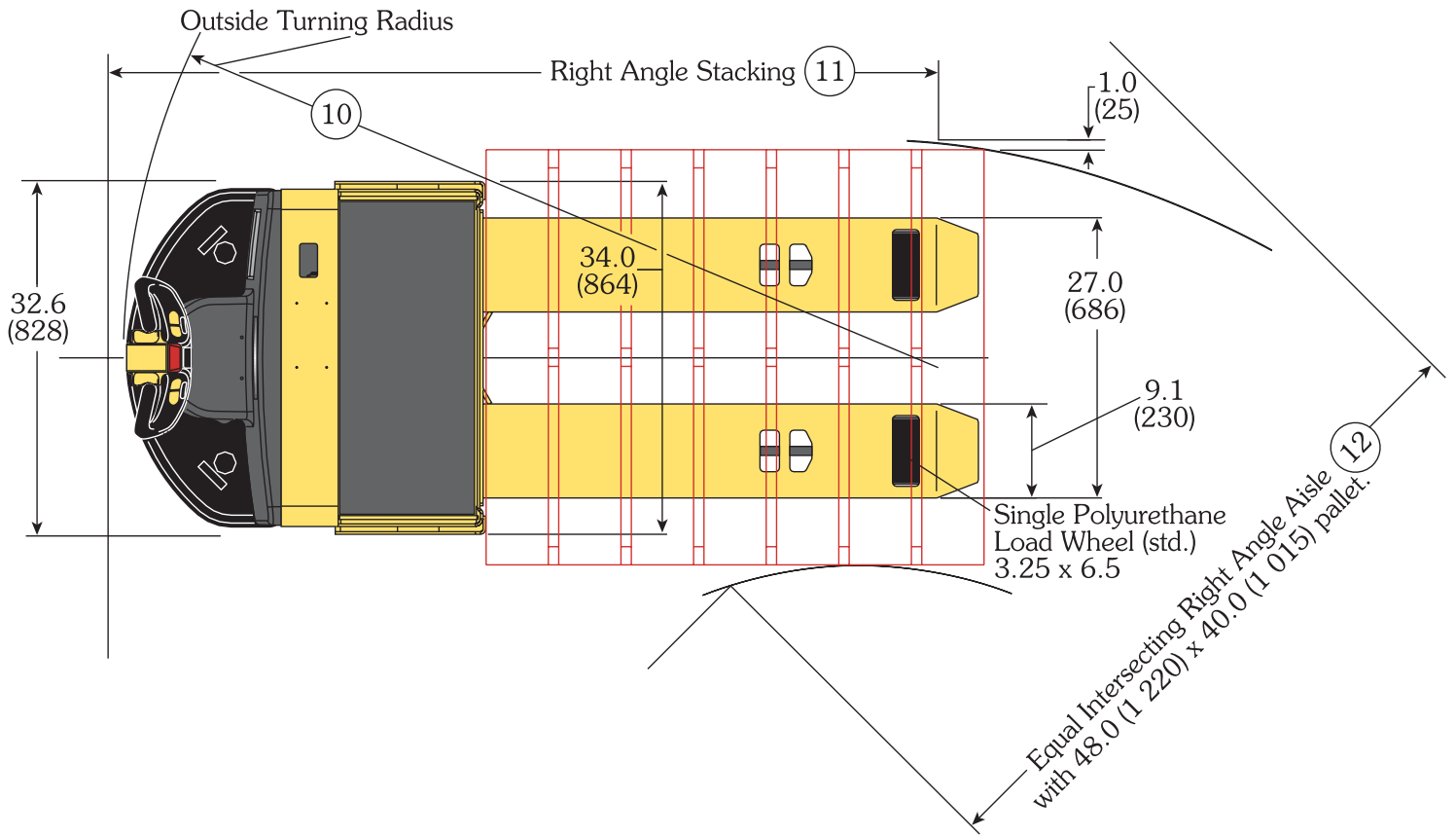

W80Z Walkie Pallet Truck Dimensions

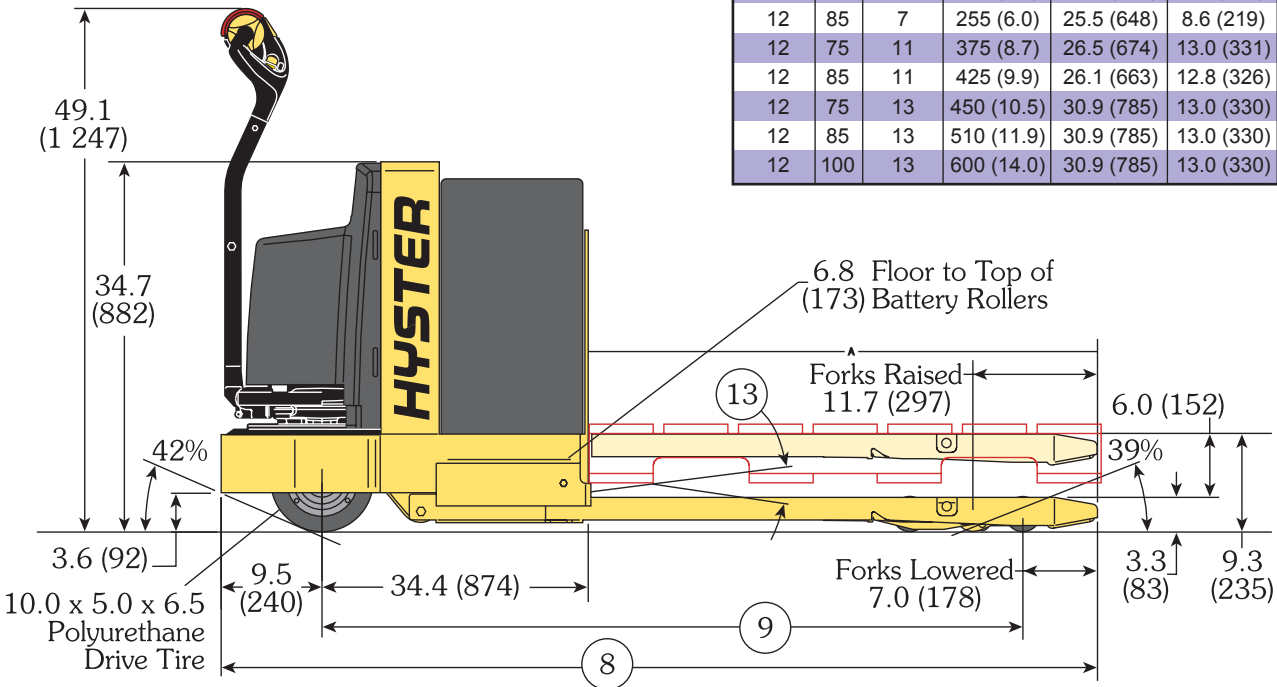

BATTERY SIZE INFORMATION							
Number Cell	Cell Size	Plates Per Cell	Capacity Ah (Kwh)	Length in. (mm)	Width in. (mm)	Height in. (mm)	Weight lbs. (kg)
12	75	7	225 (5.2)	25.6 (651)	8.8 (224)	23.3 (592)	536 (243)
12	85	7	255 (6.0)	25.5 (648)	8.6 (219)	23.3 (592)	590 (269)
12	75	11	375 (8.7)	26.5 (674)	13.0 (331)	23.3 (592)	825 (374)
12	85	11	425 (9.9)	26.1 (663)	12.8 (326)	23.3 (592)	865 (392)
12	75	13	450 (10.5)	30.9 (785)	13.0 (330)	23.3 (592)	987 (448)
12	85	13	510 (11.9)	30.9 (785)	13.0 (330)	23.3 (592)	1,035 (469)
12	100	13	600 (14.0)	30.9 (785)	13.0 (330)	26.2 (665)	1,140 (517)



**Circled dimensions correspond to the line numbers on the tabulated charts.
Dimensions are in inches (millimeters).**



W80Z Walkie Pallet Truck Specifications

GENERAL		Hyster Company	Hyster Company	Hyster Company
1	Manufacturer	Hyster Company	Hyster Company	Hyster Company
2	Model	W80Z	W80Z	W80Z
3	Capacity, rated lb. (kg)	8,000 (3 628)	8,000 (3 628)	8,000 (3 628)
4	Voltage	24	24	24
DIMENSIONS				
5	Nominal fork length in. (mm)	36.0 (915)	42.0 (1 067)	48.0 (1 219)
6	Width across forks in. (mm)	27.0 (685)	27.0 (685)	27.0 (685)
7	Chassis length, with 13.4" battery compartment in. (mm)	34.4 (874)	34.4 (874)	34.4 (874)
8	Overall length, with 13.4" battery compartment in. (mm)	70.2 (1 783)	76.2 (1 935)	82.2 (2 087)
9	Wheelbase, lowered with 13.4" battery compartment in. (mm)	53.8 (1 367)	59.8 (1 519)	65.8 (1 670)
	Wheelbase, raised with 13.4" battery compartment in. (mm)	49.1 (1 247)	55.1 (1 400)	61.1 (1 551)
10	Turning radius, lowered, with 13.4" battery compartment in. (mm)	63.2 (1 605)	69.2 (1 758)	75.2 (1 910)
	Turning radius, raised, with 13.4" battery compartment in. (mm)	58.5 (1 485)	64.5 (1 638)	70.5 (1 790)
11	Right angle aisle, 13.4" batt. comp. w/ 40"x 48" pallet in. (mm)	71.2 (1 808)	76.6 (1 946)	82.1 (2 096)
12	Equal intersecting aisle, 13.4" batt. comp. w/ 40.0" wide pallet in. (mm)	56.5 (1 435)	59.8 (1 519)	62.9 (1 596)
	Grade clearance, center wheelbase, raised with pallet %	39	34	31
	Grade clearance, forks first, raised with pallet %	39	39	39
	Grade clearance, chassis first, raised with pallet %	42	42	42
14	Overall lift height (TOF) in. (mm)	9.3 (236)	9.3 (236)	9.3 (236)
15	Overall fork lifting height in. (mm)	6.0 (154)	6.0 (154)	6.0 (154)
BATTERY				
16	Battery compartment size, 13.4" batt. compartment (L x W x H)* in.	32.0 x 13.4 x 31.0	32.0 x 13.4 x 31.0	32.0 x 13.4 x 31.0
	Battery compartment size, 13.4" batt. compartment (L x W x H)* (mm)	(812 x 340 x 787)	(812 x 340 x 787)	(812 x 340 x 787)
18	Battery weight, 13.4" batt. compartment, 24-Volt - minimum lb. (kg)	536 (243)	536 (243)	536 (227)
	Battery weight, 13.4" batt. compartment, 24-Volt - maximum lb. (kg)	1,140 (517)	1,140 (517)	1,140 (517)
PERF †				
19	Travel speed, NL / RL mph (km/h)	3.6 (5.8) / 2.4 (3.9)	3.6 (5.8) / 2.4 (3.9)	3.6 (5.8) / 2.4 (3.9)
20	Lift / lower speed, w/ 13.4" batt. compartment, 24-Volt NL seconds	3.7 / 5.9	3.7 / 5.9	3.7 / 5.9
	Lift / lower speed, w/ 13.4" batt. compartment, 24-Volt RL seconds	5.4 / 3.2	5.4 / 3.2	5.4 / 3.2
WHL				
21	Drive tire size (Polyurethane) in.	10.0 x 5.0	10.0 x 5.0	10.0 x 5.0
22	Load wheel size, Single (Polyurethane) in.	3.25 x 6.5	3.25 x 6.5	3.25 x 6.5
23	Weight, total approx. with 13.4" batt. compartment w/o battery lb. (kg)	1,006 (456)	1,033 (468)	1,060 (480)
<p>* Length is measured side to side of truck. Width is measured front to back on the truck. W80Z Pallet Trucks use 175 Amp Red connector - 16.0" (406 mm) 1/0 gauge leads, B position. Number of plates for the industrial battery is 7 to 13, depending on the Amp Hour rating chosen. Maximum battery height with optional Load Backrest Extension (LBE) and battery rollers is up to 31.0" (787mm). The W80Z Walkie pallet truck can utilize a battery with a maximum battery Amp hours of 600 Ah (14.0 kw).</p>				

Certification: These Hyster lift trucks meet design specifications of Part II ANSI B56.1-1993, as required by OSHA Section 1910.178 (a) (2) and also comply with Part III ANSI B56.1-revision in effect at time of manufacture. Certification of compliance with the applicable ANSI standards appears on the lift truck.

† Note: Performance specifications are for truck equipped as described under **Standard Equipment** in this Technical Guide. Performance specifications are affected by the condition of the vehicle and how it is equipped, as well as by the nature and condition of the operating area. If these specifications are critical, the proposed application should be discussed with your dealers.

Optional load wheels affect outside turning radius and right angle stacking aisles. Contact your dealer if these dimensions are critical.

GMA Pallet - Standard Dimensions

