

STATIC DIMENSIONS

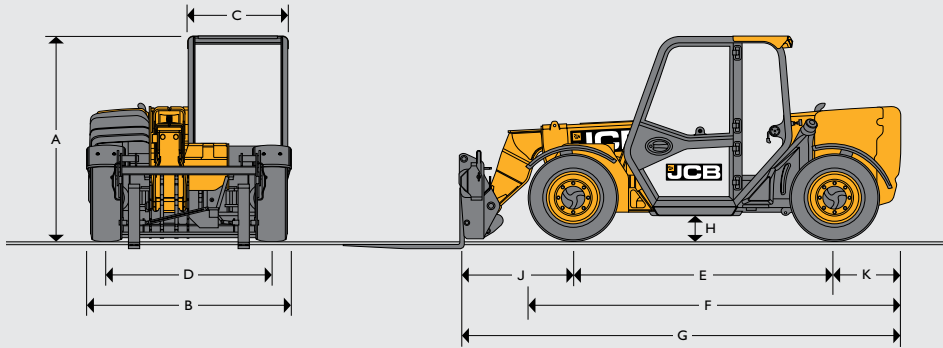

A	Overall height*	ft-in (m)	6-2 (1.89)
B	Overall width (over tires)*	ft-in (m)	6-0 (1.84)
C	Inside width of cab	ft-in (m)	2-11 (0.88)
D	Front track	ft-in (m)	5-0 (1.53)
E	Wheelbase	ft-in (m)	7-10 (2.39)
F	Overall Length to front tires	ft-in (m)	11-1 (3.38)
G	Overall length to front carriage	ft-in (m)	13-1 (4)
H	Ground clearance	ft-in (m)	0-9 (0.23)
J	Front wheel center to carriage	ft-in (m)	3-4 (1.02)
K	Rear wheel center to rear face	ft-in (m)	2-0 (0.6)
	Outside turn radius (over tires)	ft-in (m)	12-1 (3.7)
	Carriage roll back angle	degrees	11
	Carriage dump angle	degrees	114
	Weight	lb (kg)	12100 (5490)
	Tires	industrial	12 x 16.5

*Dependent upon tire specified

LIFT PERFORMANCE

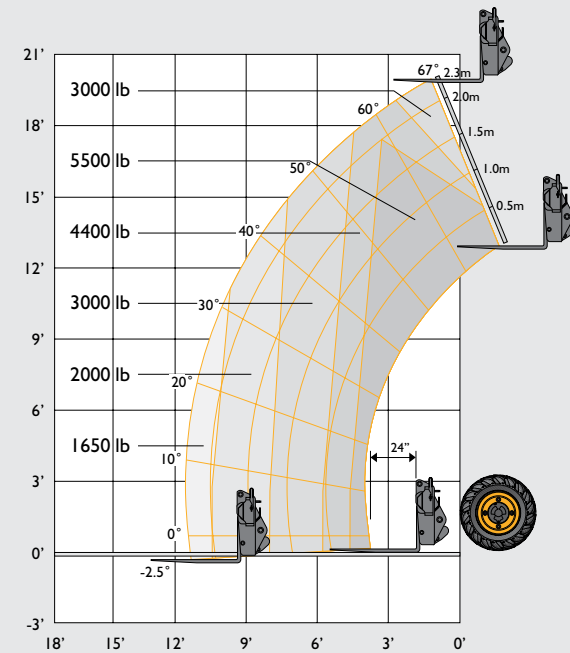

Maximum lift capacity	lb (kg)	5500 (2500)
Lift capacity to full height	lb (kg)	3900 (1750)
Lift capacity at full reach	lb (kg)	1750 (800)
Lift height	ft-in (m)	20-0 (6)
Reach at maximum lift height	in (m)	-6 (-0.15)
Maximum forward reach (to front of carriage)	ft-in (m)	11-6 (3.5)
Reach with 2,600 lbs load	ft-in (m)	8-7 (2.64)

Complies with stability test ANSI B56.6.

ENGINE

Latest Tier 4 Final technology and advanced design provides low fuel consumption, reduced noise, high torque and power output, total reliability and minimal maintenance. Two-stage, dry type air filter with primary and safety elements. Territory dependent.

Manufacturer	JCB DIESEL BY KOHLER		
Displacement	ltr	2.5	
No. of cylinders	4		
Bore size	in (mm)	3.46 (88)	
Stroke	in (mm)	4 (102)	
Aspiration	Turbocharged cooled		
Power rating			
Power @ 2200rpm	hp (kW)	74 (55)	
Torque rating			
Torque @ 1500rpm	lb-ft (Nm)	221 (300)	

HYDRAULICS

Two stage gear pump, fitted with suction strainer and filter. One boom end auxiliary hydraulic service fitted as standard.

Operating system pressure	psi (bar)	3408 (235)	
Flow at system pressure @ 2200rpm	g/min (l/min)	21 (80)	
Hydraulic cycle times		Seconds	
Boom raise	7.6		
Boom lower	5.3		
Boom extend	7.5		
Retract	3.7		
Bucket dump	1.9		
Bucket crowd	2.9		

TRANSMISSION

Closed loop variable displacement pump with a continuously variable hydrostatic drive. Comprising of a hydraulic motor and control unit. Permanent 4 wheel drive. Travel speed: 15mph (25kph).

		Forward	Reverse
Low range	mph (kph)	5 (8)	5 (8)
High range	mph (kph)	15 (25)	15 (25)

ELECTRICS

System voltage	Volt	12
Alternator output	Amp hour	80
Battery capacity	Amp hour	120

NOISE AND VIBRATION

		Uncertainty		Measurement conditions
Noise at the operator station	LpA	76 dB	+/- 1 dB	Determined in accordance with the test method defined in EN12053.
Noise emission from the machine	LWA	103 dB	+/- 1 dB	Guaranteed equivalent sound power (external noise) determined in accordance with the dynamic test conditions defined in 2000/14/EC.
Whole body vibration	m/s ²	0.37	0.18	ISO 2631-1:1997 normalised to an 8h reference period and based upon a test cycle defined in SAE J1166.
Hand-arm vibration	m/s ²	<2.5	N/A	ISO 5349-2:2001 dynamic test conditions.

AXLES

Front and rear drive axles: epicyclic hub reduction drive/steer axles with torque proportioning differentials.

BRAKES

Service brakes: Hydraulically operated self-adjusting, oil-immersed in-board multi-disc type mounted on front axle.

Parking brake: SAHR Handbrake self adjusting, oil immersed in-board multi disc type mounted on front axle operated by in-cab switch.

SERVICE FILL CAPACITIES

Hydraulic system	gal (litres)	17 (65)
Fuel tank	gal (litres)	20 (75)

BOOM AND CARRIAGE

Boom is manufactured from high tensile steel. Low maintenance, hard wearing pads. JCB Q-Fit, Skid-Steer.

STEERING

Hydrostatic power steering with power track rods on both axles.

Three steer mode options: Front wheel steer, all wheel steer, crab steer, operated from in the cab by a selection lever.

Option: In cab selector switch with Auto Align.

CAB

Quiet, safe and comfortable cab conforms to ROPS ISO 3471 and FOPS ISO 3449. Tinted, flat glass all around, with laminated roof screen. Roof bars, front screen with wipers and heater/screen demister. Rear opening window with wash/wipe. Audio-visual warning system for coolant temperature, engine oil pressure, air-cleaner, battery charge, transmission oil temperature and pressure, water in fuel, hourmeter, road speed indicator, fuel gauge, engine temperature, clock and inclinometer. Adjustable suspension seat, tilt steer column, park brake, floor mounted throttle and brake pedals.

Hydraulic controls: Single lever servo joystick, incorporating forward/neutral/reverse, with progressive extend/retract and auxiliary incorporating constant flow facility.

OPTIONS

Options: Canopy, front and rear working lights, rotating flashing beacon, fire extinguisher, front screen guard, air conditioning, 2 boom end auxiliary services, sunblind, radio kit, hydraulic locking carriage, limited slip differential in front axle, air suspension seat, 2-speed and intermittent front wash/wipers.

Attachments: Contact your local dealer for details of the comprehensive range, full road light kit, 12 volt in-cab socket, face level fan, tilt and rake steering column